

BIMETALLIC STEAM TRAPS AND AIR ELIMINATORS BM32 (DN 40 – DN 50)

DESCRIPTION

BM32 series bimetallic steam traps and air eliminators are simple and robust traps, recommended for steam process applications where condensate sensible heat can be recovered, steam tracing lines, drip points, storage tank coils, steam air venting, etc. The use of condensate sensible heat reduces steam consumption. Connections are female screwed or flanged.

MAIN FEATURES

Modulating discharge.
Discharges condensate below steam temperature.
Excellent air discharge.
Operates on superheated steam.
Unaffected by water hammer and vibrations.
Built-in strainer.

USE: Saturated and superheated steam.

AVAILABLE MODELS: BM32.

SIZES: 1 1/2" to 2"; DN 40 to DN 50.

CONNECTIONS: Female screwed BSP or NPT.
Flanged EN 1092-1 PN40 or ANSI.
SW - Socket weld to ANSI B 16.11.
BW - Butt weld to ANSI B 16.25.

INSTALLATION: Horizontal installation.
See IMI – Installation and maintenance instructions.



CE MARKING – GROUP 2 (PED – European Directive)		
ANSI 150 lb	PN40 ANSI 300 lb	Category
–	DN 40 to DN 50	1 (CE marked)
1 1/2" to 2"	–	SEP

BODY LIMITING CONDITIONS		
FLANGED PN40 / ANSI 300 lb *	FLANGED ANSI 150 lb **	RELATED TEMP.
ALLOW. PRESS.	ALLOW. PRESS.	
40 bar	19,3 bar	50 °C
35 bar	15,8 bar	150 °C
30,4 bar	12,1 bar	250 °C
27,6 bar	10,2 bar	300 °C

PMO – Max. operating pressure 32 bar

TMO – Max. operating temperature 300 °C

* According to EN1092-1:2018; ** Acc. to EN1759-1:2004;

Body limiting conditions PN40 or below, depending on the type of connection adopted.

Rating PN40 for thread, SW and BW.

FLOW RATE CAPACITY (kg/h)													
MODEL	SIZE	DIFFERENTIAL PRESSURE (bar)											
		2	4	6	8	10	12	16	18	20	24	28	32
BM32	1 1/2" to 2" A DN 40 to 50 A	450	490	550	640	700	730	850	920	980	1050	1100	1150
BM32	1 1/2" to 2" B DN 40 to 50 B	1400	1500	1700	1950	2200	2200	2600	2800	2950	3150	3300	3500

A: Condensate discharge at 10 °C below saturation temperature; B: Cold water capacity around 20 °C.

DIMENSIONS (mm)

Size	BW		BSP / NPT / SW			PN40			ANSI 150 lb			ANSI 300 lb		
	A	A	C	D	WGT. (kg)	B	F *	WGT. (kg)	B	F *	WGT. (kg)	B	F *	WGT. (kg)
1 1/2" – DN 40	160	160	132	115	7,2	75	230	11,9	64	230	10,6	78	230	12,9
2" – DN 50	160	230	132	115	9,3	83	230	14,9	76	230	14,5	83	230	16,1

* Different face to face dimensions on request.

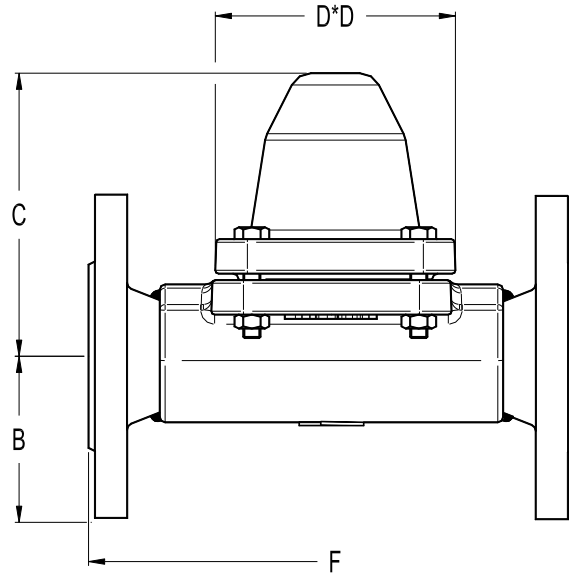
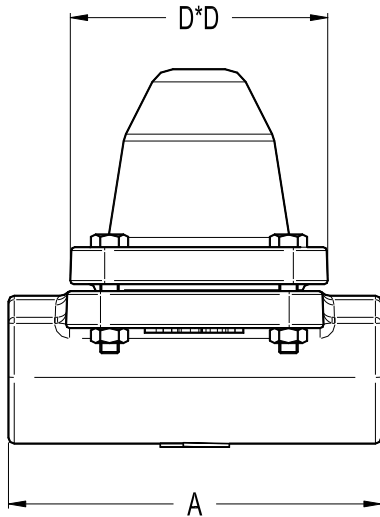

MATERIALS		
POS. N°	DESIGNATION	MATERIAL
1	Body	ASTM A105 / 1.0432 (Equiv. P250GH)
2	Cover	ASTM A105 / 1.0432 (Equiv. P250GH)
3	* Gasket	Stainless steel / Graphite
4	* Valve assembly	Hardened st. steel / Bimetal
5	* Strainer screen	AISI 304 / 1.4301
6	* Seat gasket	Copper
7	Studs	ASTM A193 Gr. B7
7A	Nuts	ASTM A194 Gr. 2H

* Available spare parts.

