

CONDENSATE DRAIN VALVES CDV32

DESCRIPTION

The CDV32 condensate drain valve automatically discharges air and condensate from steam systems during start-up. A compression spring keeps the valve open when the system is not pressurized. As soon as the operating pressure reaches the closing pressure to which the CDV is set, the valve closes. If the operating pressure drops below the closing set pressure, the spring force will cause the CDV32 to open once again.

MAIN FEATURES

Hand purging knob allowing operation with system under pressure for dirt removal.

Prevents vacuum and frost formation.

Built-in, easy-to-clean strainer.

USE: Saturated steam.

AVAILABLE

MODELS: CDV32 – carbon steel.

SIZES: 1/2" to 3/4"; DN 15 to DN 20.

CONNECTIONS: Female threaded ISO 7 Rp or NPT.
Flanged EN 1092-1 PN 40.
Flanged ASME B16.5 Class 150 or 300.
Socket weld (SW) ASME B16.11.
Butt weld (BW) ASME B16.25 on request.

INSTALLATION: Vertical installation recommended.
When installed in horizontal lines, an outlet connecting pipe pointing downwards should be installed.
See IMI – Installation and maintenance instructions.



BODY LIMITING CONDITIONS		
FLANGED PN 40 / CLASS 300 *	FLANGED CLASS 150 **	RELATED TEMP.
ALLOWABLE PRESSURE	ALLOWABLE PRESSURE	
40 bar	19,3 bar	50° C
35 bar	15,8 bar	150° C
30,4 bar	12,1 bar	250° C
27,6 bar	10,2 bar	300° C

Closing pressure: 1,5 bar.

PMO – Maximum operating pressure: 22 bar;

TMO – Maximum operating temperature: 250 °C.

* Acc. to EN 1092-1:2018. ** Acc. to EN 1759-1:2004.

Body limiting conditions PN 40 or below, depending on the type of connection adopted. Rating PN 40 for threaded, SW and BW versions.

CE MARKING – GROUP 2 (PED – European Directive)

PN 40	Category
1/2" to 3/4" – DN 15 to 20	SEP

FLOW RATE CAPACITY (kg/h)

MODEL	SIZE	DIFFERENTIAL PRESSURE (bar)								
		0,1	0,2	0,3	0,4	0,5	0,6	0,8	1	1,5
CDV32	1/2" to 3/4" DN 15 to 20	220	280	380	420	470	520	585	630	780

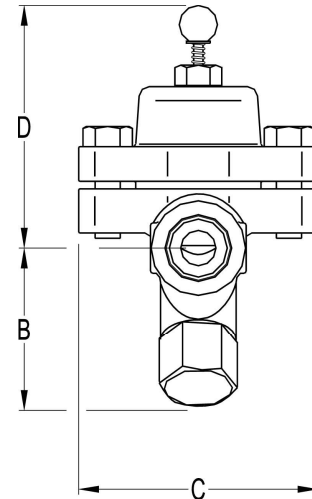
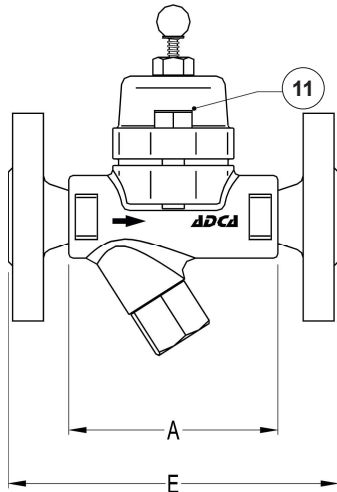

DIMENSIONS (mm)

SIZE	THREADED / SW					PN 40		CLASS 150		CLASS 300	
	A	B	C	D	WEIGHT (kg)	E	WEIGHT (kg)	E	WEIGHT (kg)	E	WEIGHT (kg)
1/2" - DN 15	95	65	95	97	1,6	150	3,2	150	2,7	150	3,5
3/4" - DN 20	95	65	95	97	1,6	150	3,9	150	3,1	150	4,7

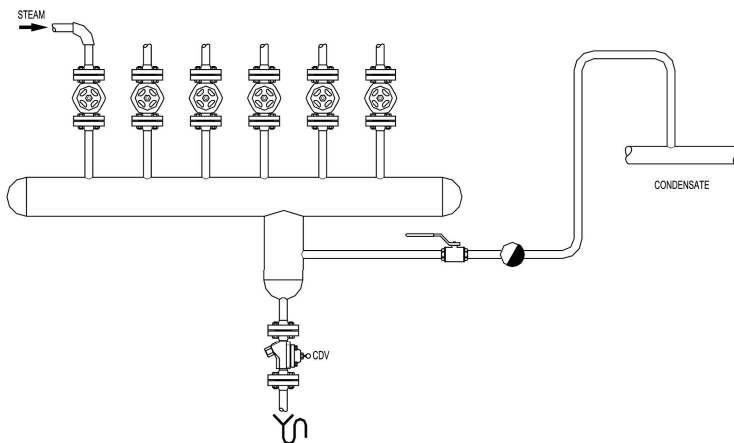

Draining a steam manifold with an elevated condensate line.

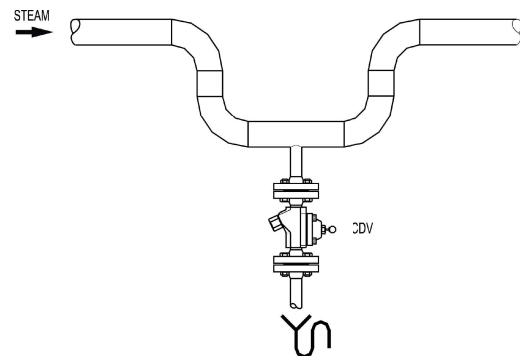

Draining a water pocket in outdoor plants, this installation also prevents freezing.

MATERIALS

POS. N°	DESIGNATION	MATERIAL
1	Body	P250GH / 1.0460
2	Cover	P250GH / 1.0460
3	* Gasket	Stainless steel / Graphite
4	* Valve controller	AISI304 / 1.4301
5	* Hand purging knob	Plastic
6	* Strainer screen	AISI 304 / 1.4301
7	* Gasket	Stainless steel / Graphite
8	Strainer cover	A105 / 1.0432
9	* Gasket	AISI 304 / 1.4301
10	* Gasket	AISI 304 / 1.4301
11	Bolts	Steel 8.8

* Available spare parts.

