

## CULINARY STEAM FILTER HOUSINGS ISC20i and ISC20i2 (Steam and gases)

### DESCRIPTION

The ADCAPure ISC20i and ISC20i2 high efficiency filters are used to remove contaminated particles from gases such as steam and compressed air.

The optimized construction of these units offers low differential pressure at high flow rates.

All sizes are built in two halves, with 1/4" to 3" being joined by a sanitary clamp ferrule according to DIN 32676 Series A. Whereas 4" to 6" are joined by bolts and nuts. All sizes include plugged drain and vent connections.

### MAIN FEATURES

Clamped body.

Fabricated from AISI 316L or CF8M for corrosion resistance and long service life.

Optimized flow paths for low pressure drop and high throughput.

Designed to comply with FDA and 3A sanitary standards for culinary steam.

### STANDARD SURFACE FINISH

Internal wetted parts upstream of filter elements:

≤ 1,6 µm Ra for model ISC20i.

As casted for model ISC20i2.

Internal wetted parts downstream of filter elements:

≤ 0,76 µm Ra – SF3, for all models.

External:

Satin bead blast finish. As casted body for model ISC20i2.

Other surface conditions see TIS.GIA – General information ADCAPure.

USE: Steam, compressed air and other gases.

### AVAILABLE

MODELS: ISC20i – AISI 316L / 1.4404 stainless steel.  
ISC20i2 – CF8M / 1.4408 body and AISI 316L / 1.4404 cover.

### FILTER

ELEMENTS: Consult respective IS information sheets.

SIZES: 1/4" to 6"; DN 10 to DN 150.

CONNECTIONS: Female threaded ISO 7 Rp or NPT.  
Tube weld (TW).  
Flanged EN 1092-1 PN 16.  
Flanged ASME B16.5 Class 150.  
Others on request.

INSTALLATION: Horizontal installation with the drain connection pointing downwards.  
See IMI – Installation and maintenance instructions.

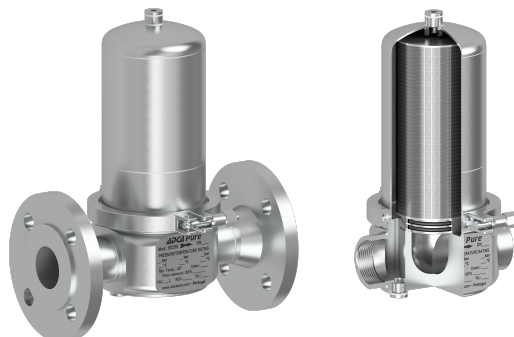

**ISC20i (AISI 316L body)**  
1/4" to 3" – DN 10 to DN 80



**ISC20i2 (CF8M body)**  
3/4" to 3" – DN 20 to DN 80

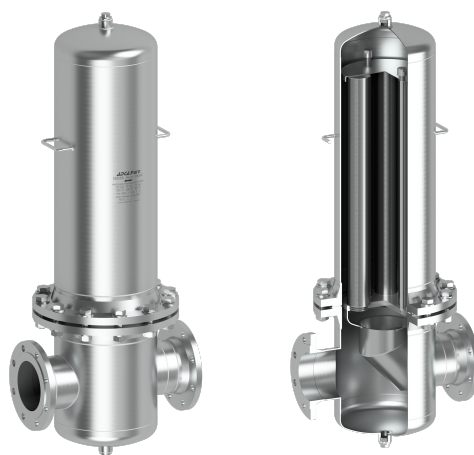

**ISC20i (AISI 316L body)**  
4" and 6" – DN 100 and DN 150

**CE MARKING – GROUP 2  
(PED – EUROPEAN DIRECTIVE)**

Ps 16 bar	Ps 12 bar	Ps 10 bar	CATEGORY
1/4" to 2"L – DN 10 to 50L	–	–	SEP
2"H to 3"L – DN 50H to 80L	3"H – DN 80H	–	1
–	–	4"L to 6"L – DN 100L to 150L	2
–	–	6"H – DN 150H	3

**LIMITING CONDITIONS \***

Maximum allowable pressure	1/4" to 3"L – DN 10 to 80L	16 bar
	3"H – DN 80H	12 bar
	4"L to 6"H – DN 100L to 150H	10 bar
Maximum allowable temperature		200 °C
Minimum allowable temperature		-20 °C
Maximum cold hydraulic test pressure	1/4" to 2 1/2" – DN 10 to 80L	28 bar
	3"H – DN 80H	24,5 bar
	4"L to 6"H – DN 100L to 150H	20 bar
Maximum differential pressure		5 bar

\* Other limits on request. Maximum operating conditions may be limited by the filter housing end connections due to normative restrictions.

**DIMENSIONS**

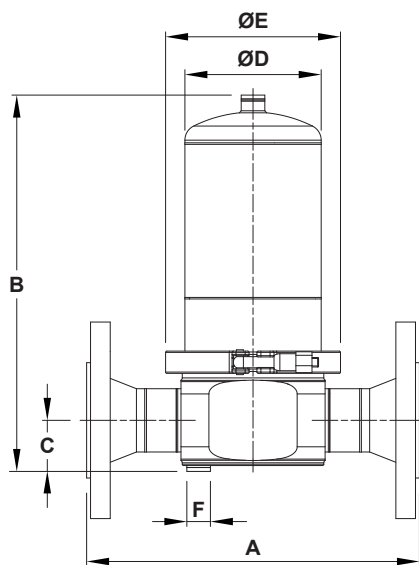

1/4" to 3" – DN 10 to DN 80

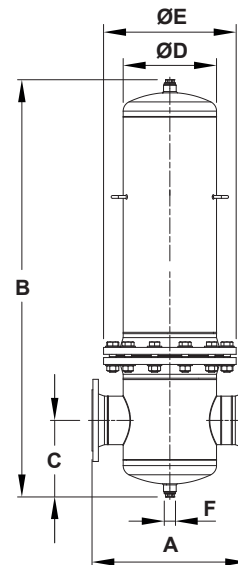

4" and 6" – DN 100 and DN 150

**DIMENSIONS – ISC20i (mm)**

SIZE *	A THREADED	A ** TUBE WELD	A PN 16	A CLASS 150	B	C	ØD	ØE	F	ØG	ØH	ISFE SIZE	ISFE QTY.	VOL. *** (L)	WGT. *** (kg)
1/4"	108	108	–	–	145	23	70	104	1/4"	13,5	10,3	0310	1	0,4	2,3
3/8" – DN 10	108	108	180	–	173	23	70	104	1/4"	17,2	14	0410	1	0,5	3,7
1/2" – DN 15	108	108	180	203	180	25	70	104	1/4"	21,3	15,8	0420	1	0,5	4,3
3/4" – DN 20	130	130	202	230	210	28	85	118	1/4"	26,7	21	0520	1	0,9	6
1" – DN 25	136	136	212	247	217	31	85	118	1/4"	33,4	27,9	0525	1	1	6,9
1 1/4" – DN 32	142	142	220	254	279	36	85	118	1/4"	42,2	36,7	0725	1	1,1	8,9
1 1/2" – DN 40	154	154	254	294	287	39	104	133	1/4"	48,3	42,8	0730	1	2,2	10,6
2"L – DN 50L	163	163	260	297	374	45	104	133	1/4"	60,3	54,8	1030	1	2,8	13
2"H – DN 50H	163	163	260	297	501	45	104	133	1/4"	60,3	54,8	1530	1	3,9	14
2 1/2" – DN 65	–	216	306	356	637	52	129	170	1/4"	76,1	68,9	2030	1	8,2	21,7
3"L – DN 80L	–	240	340	380	911	60	129	170	1/4"	88,9	82,5	3030	1	11	28,6
3"H – DN 80H	–	240	340	380	918	60	154	198	1/4"	88,9	82,5	3050	1	16	30,4
4"L – DN 100L	–	–	410	395	1070	214	219	340	1"	–	–	2030	3	34,6	65,2
4"H – DN 100H	–	–	410	395	1331	214	219	340	1"	–	–	3030	3	43,7	73,5
6"L – DN 150L	–	–	480	484	1409	256	273	405	1"	–	–	3030	4	74,1	112
6"H – DN 150H	–	–	540	534	1446	265	324	460	1"	–	–	3030	6	106,1	138

\* Suffix L corresponds to low capacity design; suffix H corresponds to high capacity design.

\*\* Tube weld (TW) ends according to ASME B36.19 or ISO 1127 depending on the size. See dimensions ØG and ØH. Other dimensions on request.

\*\*\* Volume and weight correspond to flanged EN 1092-1 PN 16 design. Weight of filter housing with filter element(s). Other designs may have slightly different values.

Remark: Other sizes on request.

**DIMENSIONS – ISC20i2 (mm)**

SIZE *	A THREADED	A ** TUBE WELD	A PN 16	A CLASS 150	B	C	ØD	ØE	F	ØG	ØH	ISFE SIZE	ISFE QTY.	VOL. *** (L)	WGT. *** (kg)
3/4" – DN 20	130	122	202	227	234	36	85	118	1/4"	26,9	22,3	0520	1	0,9	5,9
1" – DN 25	136	132	212	243	234	36	85	118	1/4"	33,7	28,5	0525	1	0,9	6,4
1 1/4" – DN 32	136	136	220	250	286	36	85	118	1/4"	42,4	37,2	0725	1	1,3	7,6
1 1/2" – DN 40	164	164	254	288	302	43	104	133	1/4"	48,3	43,1	0730	1	2	10,4
2"L – DN 50L	164	164	260	291	377	43	104	133	1/4"	60,3	54,5	1030	1	2,7	11,8
2"H – DN 50H	164	164	260	291	503	43	104	133	1/4"	60,3	54,5	1530	1	3,7	12,8
2 1/2" – DN 65	–	216	306	356	669	60	129	170	1/4"	76,1	70,3	2030	1	7,5	20,8
3"L – DN 80L	–	216	316	356	923	60	129	170	1/4"	88,9	82,5	3030	1	10,8	24,3
3"H – DN 80H	–	240	340	380	934	60	154	198	1/4"	88,9	82,5	3050	1	15,2	28,4

\* Suffix L corresponds to low capacity design; suffix H corresponds to high capacity design.

\*\* Tube weld (TW) ends according to ISO 1127. Other dimensions on request.

\*\*\* Volume and weight correspond to flanged EN 1092-1 PN 16 design. Weight of filter housing with filter element(s). Other designs may have slightly different values.

Remark: Other sizes on request.

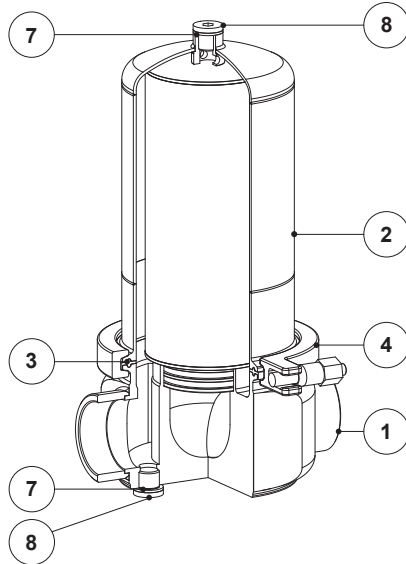

1/4" to 3" – DN 10 to DN 80

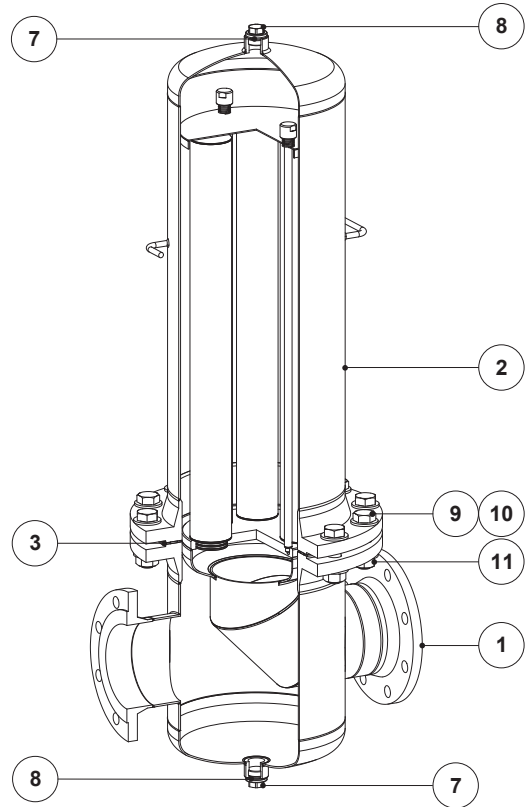

4" and 6" – DN 100 and DN 150

**MATERIALS**

POS. No.	DESIGNATION	MATERIAL
1	Filter housing body (ISC20i)	AISI 316L / 1.4404
	Filter housing body (ISC20i2)	CF8M / 1.4408
2	Filter housing cover	AISI 316L / 1.4404
3	* Seal (1/4" to 3" – DN 10 to 80)	** PTFE / FPM Envelope
	* Seal (4" and 6" – DN 100 and 150)	** PTFE
4	Safety clamp	AISI 316 / 1.4401
7	Gasket	** PTFE
8	Plug	AISI 304 / 1.4301
9	Bolt (4" and 6" – DN 100 and 150)	Stainless steel A2-70
10	Washer (4" and 6" – DN 100 and 150)	Stainless steel A2
11	Nut (4" and 6" – DN 100 and 150)	Stainless steel A2-70

\* Available spare parts. \*\* Others on request.

FDA / USP Class VI seals certificate on request.

All filters have a serial number. In case of non-standard filter, this number must be supplied if spare parts are ordered.

**TYPICAL INSTALLATION – FILTERED STEAM PRESSURE REDUCING STATION**

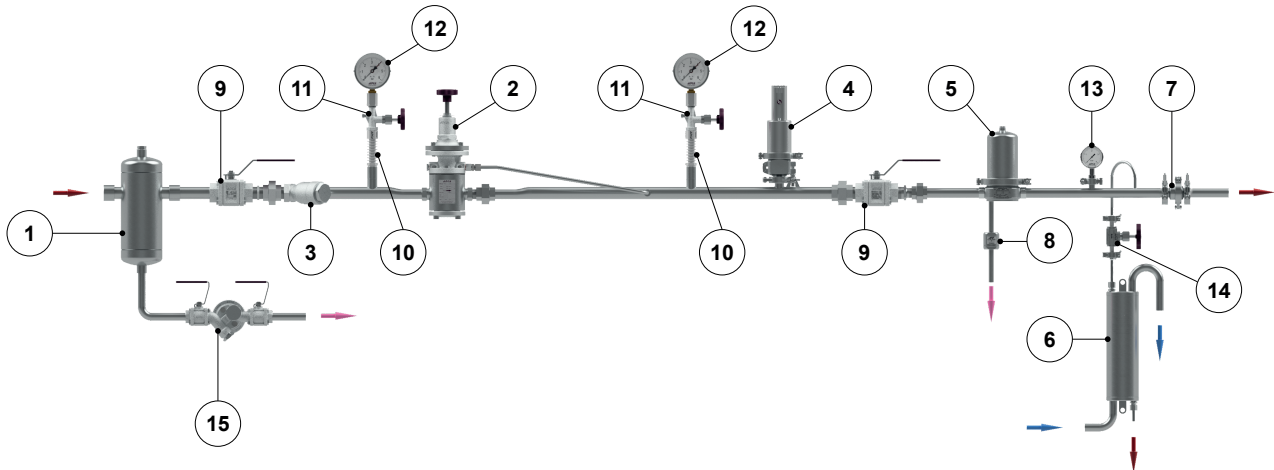

EQUIPMENT	
POS. No.	DESIGNATION
1	ADCA S16SS Centrifugal humidity separator
2	ADCA PRV47i Pilot operated pressure reducing valve
3	ADCA IS140i Y Strainer
4	ADCA Safety valve
5	ADCAPure ISC20i Culinary steam filter with 5 µm ISFE filter element
6	ADCAPure SC32P Sample cooler
7	ADCAPure SRTH10 Check valve
8	ADCA TSS22 Steam trap
9	ADCA M3i1 Three piece ball valve
10	ADCA GSV Gauge siphon
11	ADCA GC400i Gauge cock
12	ADCA MAN100i Pressure gauge
13	ADCAPure SMAN-63R Pressure gauge
14	Sanitary needle valve
15	UniADCA CTS4U Compact trapping station with UFS32 Steam trap



ORDERING CODES – ISC20i FILTER HOUSING							
FILTER MODEL	ISC20I	.	T	A	.	08	
ISC20i – AISI 316L / 1.4404 filter housing	ISC20I						
ISC20i2 – CF8M / 1.4408 body and AISI 316L / 1.4404 cover	ISC20I2						
HOUSING SEAL MATERIAL							
PTFE / FPM (1/4" to 3" – DN 10 to 80) or PTFE (4" and 6" – DN 100 and 150)			T				
PIPE CONNECTIONS							
Female threaded ISO 7 Rp (only available from 1/4" up to 2")				A			
Female threaded NPT ASME B1.20.1 (only available from 1/4" up to 2")				C			
Tube weld				H			
Flanged EN 1092-1 PN 16				L			
Flanged ASME B16.5 Class 150				U			
SIZE							
1/4"							08
3/8" or DN 10							10
...							...
3"L or DN 80L							80L
3"H or DN 80H							80H
...							...
6"L or DN 150L							150L
6" or DN 150H							150H
SPECIAL CONSTRUCTION / ADDITIONAL OPTIONS							
Full description or additional codes have to be added in case of non-standard combination							E

**HOW TO ORDER**

1 ADCAPure filter housing ISC20i with PTFE/FPM seals, threaded NPT 2"L – Code: ISC20I.TC.50L  
 1 ISFE filter element with 5 micron retention rate and EPM seals for the above mentioned filter – Code: ISFE.P1030.05  
 Remark: We recommend a second filter element set as a spare part to ensure minimum downtime when replacing the one in use after saturation.