

## FLOAT AND THERMOSTATIC STEAM TRAPS FLT27 (SG iron 11/2" – 2"; DN 40 – 50)

### DESCRIPTION

The FLT27 is a range of float and thermostatic steam traps with integral air vent designed for modulating discharge of condensate, ensuring maximum system heat transfer.

Typical applications include unit heaters, heat exchangers, dryers, jacketed vessels and other applications where continuous discharge is essential and high flow capacities are involved.

### MAIN FEATURES

- Modulating discharge of condensate at steam temperature.
- Unaffected by sudden or wide load and pressure variations.
- No backing-up with condensate.
- Excellent air discharge through its integrated air vent.
- Flow direction can be easily changed by repositioning the body in relation to the mechanism and cover.

- OPTIONS:**
- Equalizing (vent) and drain connections.
  - SLR – Steam lock release.
  - HVV – Hand vent valve.
  - BDV – Blowdown valve.
  - AFZ – Anti-freeze device.
  - FLL – Float lifting lever.
  - VB21M – Vacuum breaker.

**USE:** Saturated and superheated steam.

**AVAILABLE MODELS:** FLT27-4,5 , 10 and 14 – SG iron.

**SIZES:** 11/2" to 2"; DN 40 to DN 50.

**CONNECTIONS:** Female threaded ISO 7 Rp or NPT.  
Flanged EN 1092-2 PN 16.  
Flanged ASME B16.42 Class 150.

**INSTALLATION:** Horizontal or vertical installation.

**MAX. ΔP:**  
FLT27-4,5 – 4,5 bar  
FLT27-10 – 10 bar  
FLT27-14 – 14 bar



CE MARKING – GROUP 2 (PED – European Directive)	
PN 16	Category
11/2" to 2" – DN 40 to 50	SEP

BODY LIMITING CONDITIONS		
FLANGED PN 16 *	FLANGED CLASS 150 **	RELATED TEMP.
ALLOWABLE PRESSURE	ALLOWABLE PRESSURE	
16 bar	16 bar	100 °C
15,5 bar	14,8 bar	150 °C
14,7 bar	13,9 bar	200 °C
13,9 bar	12,1 bar	250 °C

PMO – Maximum operating pressure: 14 bar.  
TMO – Maximum operating temperature: 198 °C.  
\* Acc. to EN 1092-2:2018; \*\* Acc. to ASME B16.42.  
Body limiting conditions PN 16 or below, depending on the type of connection adopted. Rating PN 16 for threaded versions.

FLOW RATE CAPACITY (kg/h)										
MODEL	SIZE	DIFFERENTIAL PRESSURE (bar)								
		0,5	1	1,5	2	4,5	7	10	12	14
FLT27-4,5	1 1/2" to 2" – DN 40 to 50	2400	3400	3900	4500	7300	–	–	–	–
FLT27-10	1 1/2" to 2" – DN 40 to 50	1500	2000	2600	3000	4000	5400	6200	–	–
FLT27-14	1 1/2" to 2" – DN 40 to 50	950	1300	1600	1800	2600	3250	3900	4210	4950

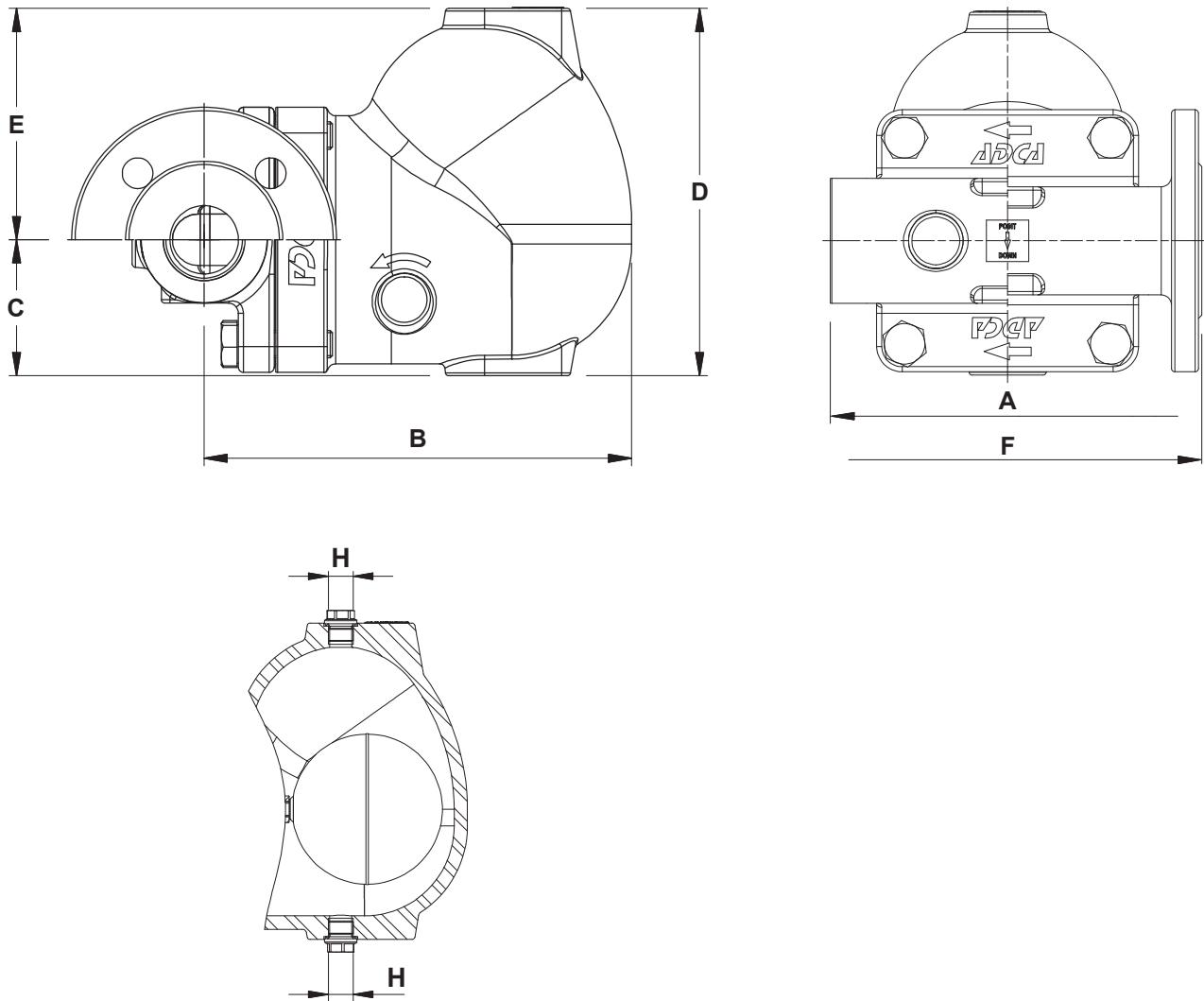

DIMENSIONS (mm)											
SIZE	THREADED							PN 16		CLASS 150	
	A	B	C	D	E	H *	WEIGHT (kg)	F	WEIGHT (kg)	F	WEIGHT (kg)
1 1/2" – DN 40	210	250	80	215	136	3/8"	19	230	21,9	230	20,4
2" – DN 50	210	250	80	215	136	3/8"	18,4	230	23,8	230	21,7

\* As standard, in versions with EN flanges or female ISO 228 threads, these connections are female threaded ISO 228. In versions with ASME flanges or female NPT threads, these connections are female threaded NPT.

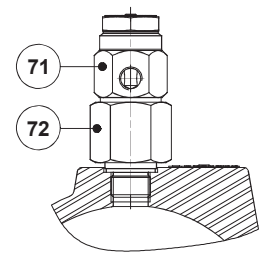
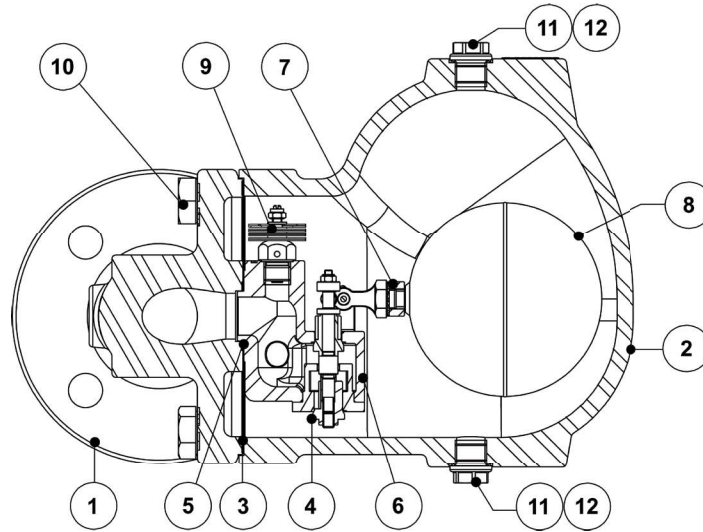

VB21M - Vacuum breaker

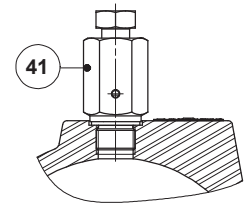

HVV - Hand vent valve

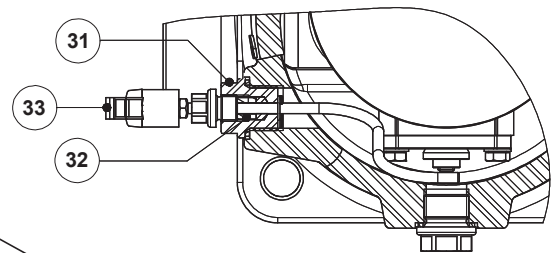

FLL - Float lifting lever

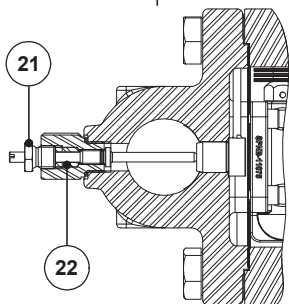

SLR - Steam lock release

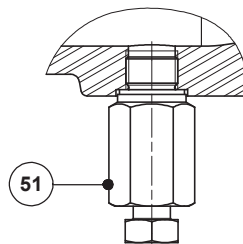

BDV - Blowdown valve  
(Manual)

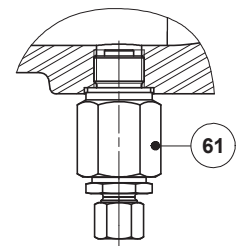

AFZ - Anti-freeze device  
(Automatic)

MATERIALS		
POS. N°	DESIGNATION	MATERIAL
1	Body	GJS-400-15 / 0.7040
2	Cover	GJS-400-15 / 0.7040
3	* Gasket	Stainless steel / Graphite
4	* Seat	A351 CF8 / 1.4308; A276-98B / 1.4057
5	* Gasket	Graphite
6	* Valve	AISI 316 / 1.4401; AISI 420 / 1.4021
7	* Lever	A351 CF8M / 1.4408
8	* Float	AISI 304 / 1.4301
9	* Automatic air vent	Stainless steel (bimetallic)
10	Bolts	Zinc plated steel
11	Plug	AISI 316L / 1.4404
12	** Gasket	Copper; AISI 304 / 1.4301
21	Steam Lock Release	AISI 420 / 1.4021 AISI 316L / 1.4404
22	Packing	Graphite
31	Lever mechanism	AISI 303 / 1.4305 ; AISI 304 / 1.4301; AISI 316L / 1.4404
32	Packing	Graphite
33	Lever	Plastic
41	Hand vent valve	AISI 303 / 1.4305; AISI 316L / 1.4404
51	Blowdown valve	AISI 303 / 1.4305; AISI 316L / 1.4404
61	Anti-freeze device	AISI 303 / 1.4305; AISI 316L / 1.4404
71	Vacuum breaker	AISI 303 / 1.4305
72	Adapter fitting	AISI 303 / 1.4305

\* Available spare parts; \*\* Not applicable in NPT version.

**FLOW DIRECTION**

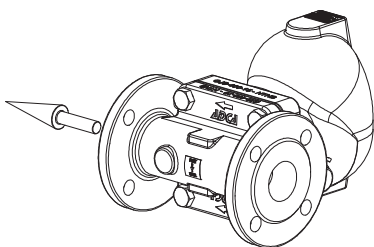

*IR - Horizontal from right to left*

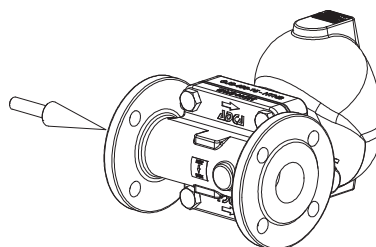

*IL - Horizontal from left to right*

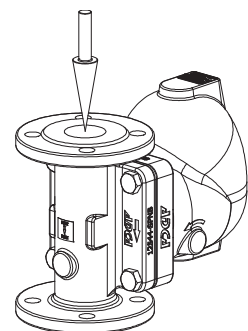

*IT - Vertical from top to bottom*

ORDERING CODES FLT27										
<b>Model</b>	A27	2	V	XX	X	X	IR	A	40	
FLT27 – GJS-400-15 / 0.7040 SG iron	A27									
<b>Differential pressure</b>										
4,5 bar		2								
10 bar		3								
14 bar		4								
<b>Automatic air vent</b>										
Bimetallic air vent (standard)			V							
None			X							
<b>Cover connections</b>										
None				XX						
3/8" threaded connections on top and bottom, closed with plugs (mandatory if any options are considered)				10						
<b>Options</b>										
If any, these have specific separate ordering codes, please refer to the appropriate documentation.										
<b>SLR - Steam lock release</b>										
None					X					
With steam lock release assembled					S					
<b>FLL - Float lifting lever</b>										
None						X				
Lifting lever on the right side (when facing the steam trap body)						R				
Lifting lever on the left side (when facing the steam trap body)						L				
<b>Flow direction</b>										
Horizontal from right to left (standard)							IR			
Horizontal from left to right							IL			
Vertical from top to bottom							IT			
<b>Pipe connections</b>										
Female threaded ISO 7 Rp								A		
Female threaded NPT								C		
Flanged EN 1092-2 PN 16								L		
Flanged ASME B16.42 Class 150								U		
<b>Size</b>										
11/2" or DN 40									40	
2" or DN 50									50	
<b>Special valves / Extras</b>										
Full description or additional codes have to be added in case of a non-standard combination										E