

FLOAT AND THERMOSTATIC STEAM TRAPS FLT35 (Carbon steel 1"; DN 25)

DESCRIPTION

The FLT35 is a series of float and thermostatic steam traps with integral air vent designed for modulating discharge of condensate, ensuring maximum system heat transfer.

Typical applications include unit heaters, heat exchangers, dryers, jacketed vessels and other applications where continuous discharge is essential.

MAIN FEATURES

- Modulating discharge of condensate at steam temperature.
- Unaffected by sudden or wide load and pressure variations.
- No backing-up with condensate.
- Excellent air discharge through its integrated air vent.
- Flow direction can be easily changed by repositioning the body in relation to the mechanism and cover.

- OPTIONS:**
- Equalizing (vent) and drain connections.
 - SLR – Steam lock release.
 - HVV – Hand vent valve.
 - BDV – Blowdown valve.
 - AFZ – Anti-freeze device.
 - FLL – Float lifting lever.
 - VB21M – Vacuum breaker.

USE: Saturated and superheated steam.

AVAILABLE MODELS: FLT35-4,5 , 10, 14, 21 and 32 – carbon steel.

SIZES: 1"; DN 25.

CONNECTIONS: Female threaded ISO 7 Rp or NPT.
Flanged EN 1092-1 PN 40.
Flanged ASME B16.5 Class 150 or 300.
Socket weld (SW) ASME 16.11.

INSTALLATION: Inline horizontal or vertical installation.
Angled horizontal or vertical installation.
See IMI – Installation and maintenance instructions.

MAX. ΔP:

- FLT35-4,5 – 4,5 bar
- FLT35-10 – 10 bar
- FLT35-14 – 14 bar
- FLT35-21 – 21 bar
- FLT35-32 – 32 bar



CE MARKING – GROUP 2 (PED – European Directive)

CLASS 150	PN 40	Category
1" – DN 25	–	SEP
–	1" – DN 25	1 (CE marked)

BODY LIMITING CONDITIONS		
FLANGED PN 40 / CLASS 300 *	FLANGED CLASS 150 **	RELATED TEMP.
ALLOWABLE PRESSURE	ALLOWABLE PRESSURE	
37,1 bar	17,7 bar	100 °C
33,3 bar	14 bar	200 °C
30,4 bar	12,1 bar	250 °C
27,6 bar	10,2 bar	300 °C

PMO – Maximum operating pressure: 32 bar.
TMO – Maximum operating temperature: 250 °C.
* Acc. to EN 1092-1:2018; ** Acc. to EN 1759-1:2004.
Body limiting conditions PN 40 or below, depending on the type of connection adopted. Rating PN 40 for threaded and SW versions.

FLOW RATE CAPACITY (kg/h)														
MODEL	SIZE	DIFFERENTIAL PRESSURE (bar)												
		0,5	1	1,5	2	4,5	7	10	12	14	16	21	25	32
FLT35-4,5	1" – DN 25	900	1250	1490	1630	2490	–	–	–	–	–	–	–	–
FLT35-10	1" – DN 25	445	610	705	850	1285	1670	1820	–	–	–	–	–	–
FLT35-14	1" – DN 25	335	445	515	600	885	1150	1350	1500	1610	–	–	–	–
FLT35-21	1" – DN 25	255	335	380	410	555	680	745	790	815	895	920	–	–
FLT35-32	1" – DN 25	230	275	315	345	440	500	570	600	610	650	705	750	810

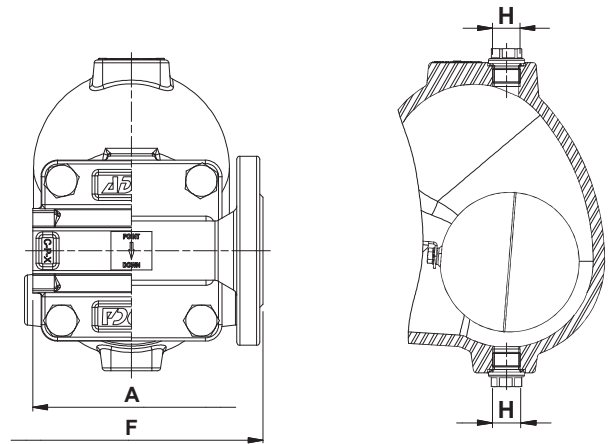
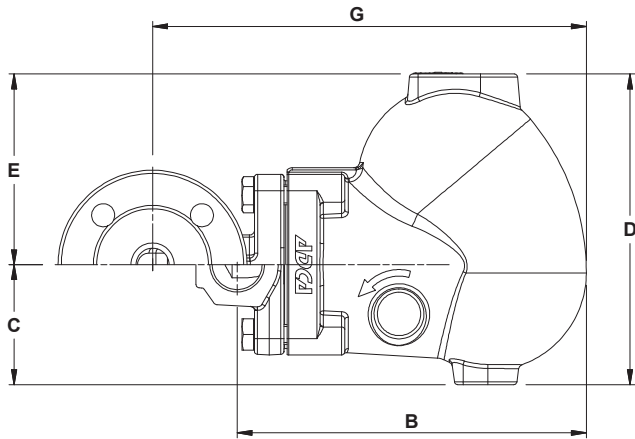

Inline design

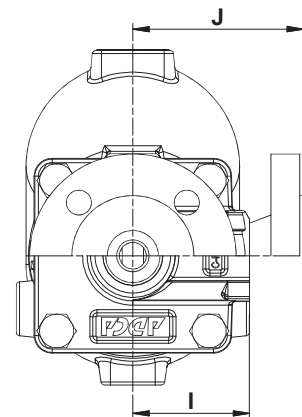
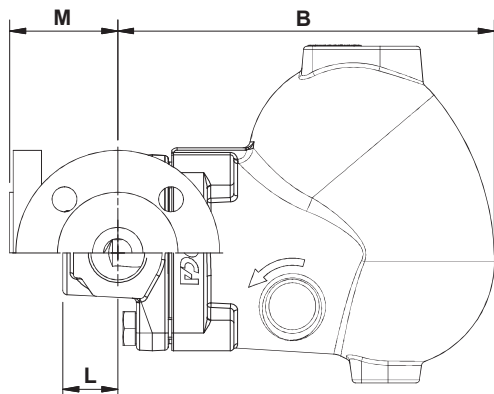

Angled design

DIMENSIONS (mm) – INLINE DESIGN

SIZE	THREADED / SW							PN 40			CLASS 150			CLASS 300		
	A	B	C	D	E	H*	WGT. (kg)	F	G	WGT. (kg)	F	G	WGT. (kg)	F	G	WGT. (kg)
1" – DN 25	120	212	73	189	116	3/8"	8,9	160	264	12	160	264	11,9	160	264	12,6

* As standard, in versions with EN flanges or female ISO 7 Rp threads, these connections are female threaded ISO 228. In versions with ASME flanges, female NPT threads or SW, these connections are female threaded NPT.

DIMENSIONS (mm) – ANGLED DESIGN

SIZE	THREADED / SW								PN 40			CLASS 150			CLASS 300		
	B	C	D	E	H*	I	L	WGT. (kg)	J	M	WGT. (kg)	J	M	WGT. (kg)	J	M	WGT. (kg)
1" – DN 25	212	73	189	116	3/8"	65	31	8,4	95	61	11	100	66	10,5	110	76	11,7

* As standard, in versions with EN flanges or female ISO 7 Rp threads, these connections are female threaded ISO 228. In versions with ASME flanges, female NPT threads or SW, these connections are female threaded NPT.

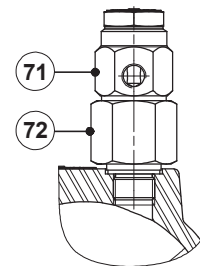
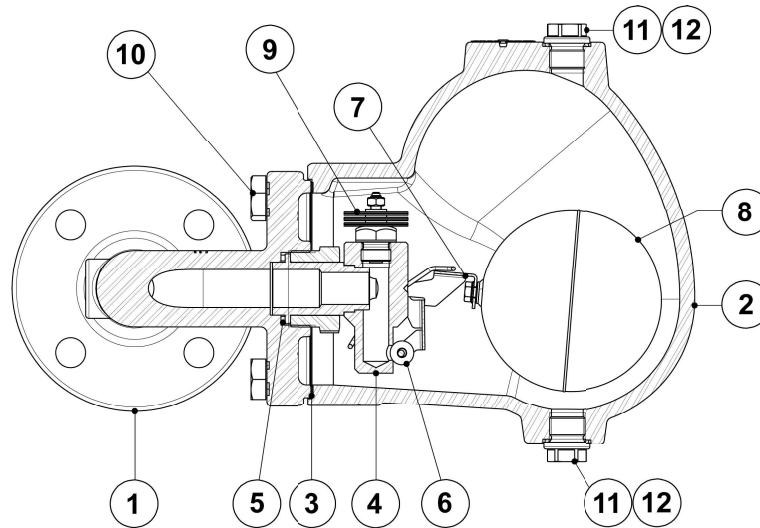

VB21M - Vacuum breaker

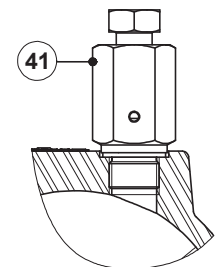

HVV - Hand vent valve

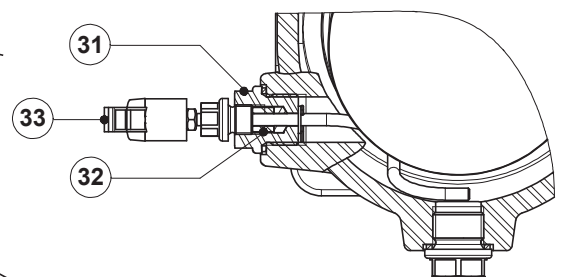

FLL - Float lifting lever

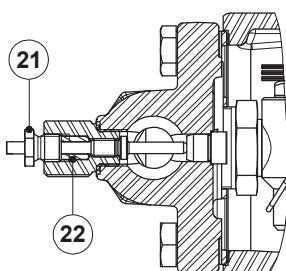

SLR - Steam lock release

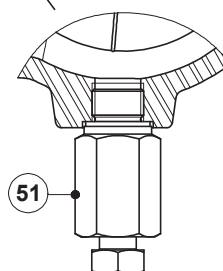

BDV - Blowdown valve
(Manual)

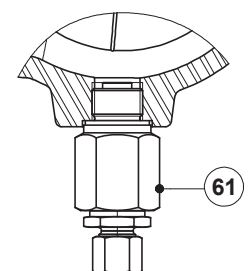

AFZ - Anti-freeze device
(Automatic)

MATERIALS		
POS. N°	DESIGNATION	MATERIAL
1	Body (inline flanged)	A216 WCB / 1.0619
	Body (inline threaded)	P250GH / 1.0460
	Body (angled)	P250GH / 1.0460
2	Cover	A216 WCB / 1.0619
3	* Gasket	Stainless steel / Graphite
4	* Seat	AISI 303 / 1.4305
5	* Gasket	Copper
6	* Valve ball	AISI 316 / 1.4401
7	* Lever	AISI 304 / 1.4301
8	* Float	AISI 304 / 1.4301
9	* Automatic air vent	Stainless steel; Bimetallic
10	Bolts	Zinc plated steel
11	Plug	AISI 316L / 1.4404
12	** Gasket	Copper; AISI 304 / 1.4301
21	Steam Lock Release	AISI 420 / 1.4021 AISI 316L / 1.4404
22	Packing	Graphite
31	Lever mechanism	AISI 303 / 1.4305 ; AISI 304 / 1.4301; AISI 316L / 1.4404
32	Packing	Graphite
33	Lever	Plastic
41	Hand vent valve	AISI 303 / 1.4305; AISI 316L / 1.4404
51	Blowdown valve	AISI 303 / 1.4305; AISI 316L / 1.4404
61	Anti-freeze device	AISI 303 / 1.4305; AISI 316L / 1.4404
71	Vacuum breaker	AISI 303 / 1.4305
72	Adapter fitting	AISI 303 / 1.4305

* Available spare parts; ** Not applicable in NPT version.

FLOW DIRECTION

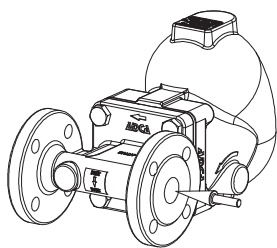

IR - Horizontal from right to left

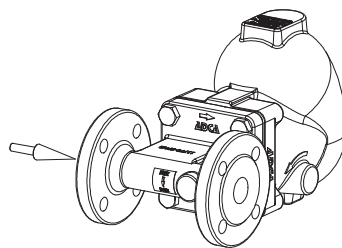

IL - Horizontal from left to right

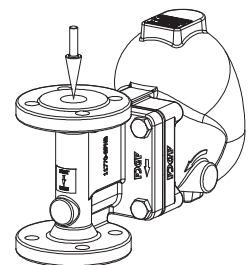

IT - Vertical from top to bottom

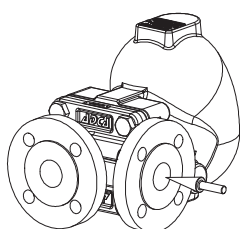

AR - Angled from right to front

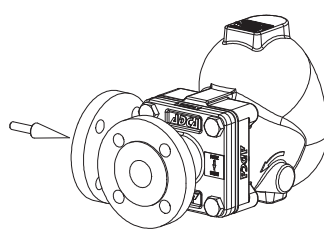

AL - Angled from left to front

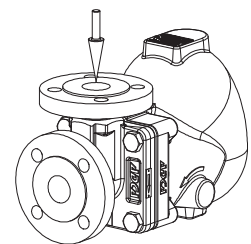

AT - Angled from top to front

ORDERING CODES FLT35										
Model	A35	2	V	XX	X	X	IR	A	25	
FLT35 – Carbon steel	A35									
Differential pressure										
4,5 bar		2								
10 bar		3								
14 bar		4								
21 bar		5								
32 bar		7								
Automatic air vent										
Bimetallic air vent (standard)			V							
None			X							
Cover connections										
None				XX						
3/8" threaded connections on top and bottom, closed with plugs (mandatory if any options are considered)				10						
Options										
If any, these have specific separate ordering codes, please refer to the appropriate documentation.										
SLR - Steam lock release										
None					X					
With steam lock release assembled (not available for angled design versions)					S					
FLL - Float lifting lever										
None						X				
Lifting lever on the right side (when facing the steam trap body)							R			
Lifting lever on the left side (when facing the steam trap body)							L			
Flow direction										
Inline horizontal from right to left (standard)								IR		
Inline horizontal from left to right								IL		
Inline vertical from top to bottom								IT		
Angled from right to front								AR		
Angled from left to front								AL		
Angled from top to front								AT		
Pipe connections										
Female threaded ISO 7 Rp									A	
Female threaded NPT									C	
Socket weld (SW) ASME 16.11									H	
Flanged EN 1092-1 PN 40									N	
Flanged ASME B16.5 Class 150									U	
Flanged ASME B16.5 Class 300									V	
Size										
1" or DN 25										25
Special valves / Extras										
Full description or additional codes have to be added in case of a non-standard combination										E