

FLOAT AND THERMOSTATIC STEAM TRAPS

FLT39

(Carbon steel 2"; DN 50)

DESCRIPTION

The FLT39 is a range of float and thermostatic steam traps with integral air vent designed for modulating discharge of condensate, ensuring maximum system heat transfer.

Typical applications include unit heaters, heat exchangers, dryers, jacketed vessels and other applications where continuous discharge is essential and high flow capacities are involved.

MAIN FEATURES

- Modulating discharge of condensate at steam temperature.
- Unaffected by sudden or wide load and pressure variations.
- No backing-up with condensate.
- Excellent air discharge through its integrated air vent.
- Flow direction can be easily changed by repositioning the body in relation to the mechanism and cover.

- OPTIONS:
- Equalizing (vent) and drain connections.
 - SLR – Steam lock release.
 - HVV – Hand vent valve.
 - BDV – Blowdown valve.
 - AFZ – Anti-freeze device.
 - FLL – Float lifting lever.
 - VB21M – Vacuum breaker.

USE: Saturated and superheated steam.

AVAILABLE MODELS: FLT39-4,5 , 10 , 21 and 32 – carbon steel.

SIZES: 2"; DN 50.

- CONNECTIONS:
- Female threaded ISO 7 Rp or NPT.
 - Flanged EN 1092-1 PN 40.
 - Flanged ASME B16.5 Class 150 or 300.
 - Socket weld ASME B16.11.

INSTALLATION: Horizontal or vertical installation.

- MAX. ΔP:
- FLT39-4,5 – 4,5 bar
 - FLT39-10 – 10 bar
 - FLT39-21 – 21 bar
 - FLT39-32 – 32 bar



CE MARKING – GROUP 2 (PED – European Directive)	
PN 40	Category
2" – DN 50	1 (CE marked)

BODY LIMITING CONDITIONS		
FLANGED PN 40 / CLASS 300 *	FLANGED CLASS 150 **	RELATED TEMP.
ALLOWABLE PRESSURE	ALLOWABLE PRESSURE	
40 bar	17,7 bar	100 °C
40 bar	14 bar	200 °C
39 bar	12,1 bar	250 °C
35,2 bar	10,2 bar	300 °C

PMO – Maximum operating pressure: 32 bar.
TMO – Maximum operating temperature: 250 °C.
* Acc. to EN 1092-1:2018; ** Acc. to EN 1759-1:2004.
Body limiting conditions PN 40 or below, depending on the type of connection adopted. Rating PN 40 for threaded and SW versions.

FLOW RATE CAPACITY (kg/h)														
MODEL	SIZE	DIFFERENTIAL PRESSURE (bar)												
		0,5	1	1,5	2	4,5	7	10	12	14	16	21	25	32
FLT39-4,5	2" – DN 50	7550	11000	14000	15500	22500	–	–	–	–	–	–	–	–
FLT39-10	2" – DN 50	3900	5000	6100	7100	10000	13750	16000	–	–	–	–	–	–
FLT39-21	2" – DN 50	1900	2700	3100	3600	5000	6900	8100	9000	9800	10050	11150	–	–
FLT39-32	2" – DN 50	1900	2700	3100	3600	5000	6900	8100	9000	9800	10050	11150	12000	12550

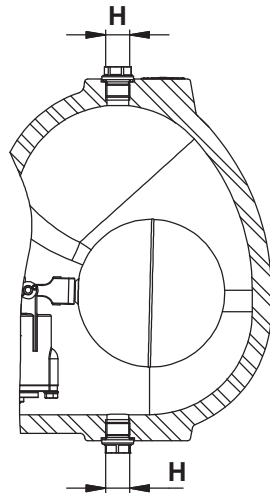
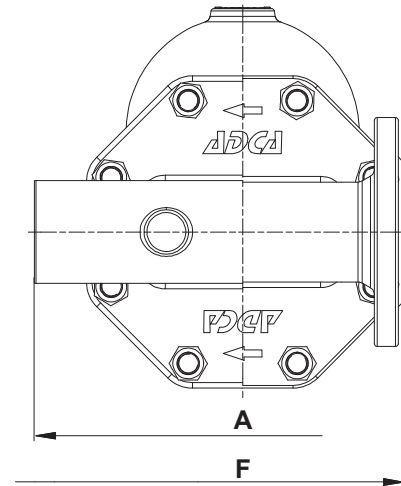
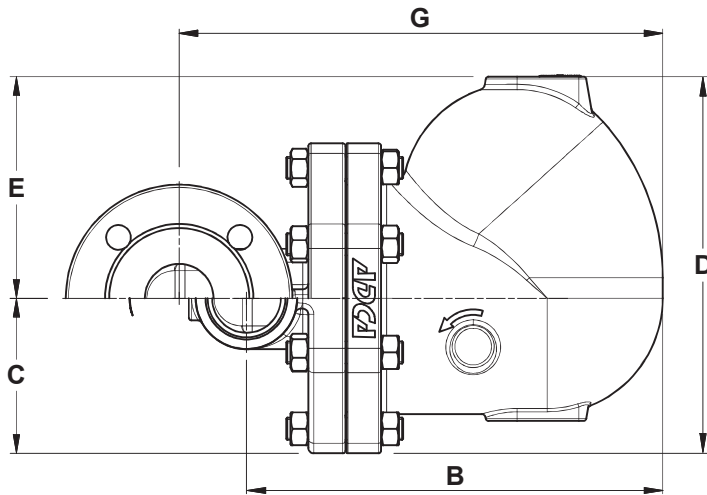

DIMENSIONS (mm)																
SIZE	THREADED / SW							PN 40			CLASS 150			CLASS 300		
	A	B	C	D	E	H*	WGT. (kg)	F	G	WGT. (kg)	F	G	WGT. (kg)	F	G	WGT. (kg)
2" – DN 50	300	303	80	215	136	3/8"	35,5	230	352	40,8	230	352	39,9	230	352	40,4

* As standard, in versions with EN flanges and female ISO 7 Rp threads, these connections are female threaded ISO 228. In versions with ASME flanges, female NPT threads or SW, these connections are female threaded NPT.

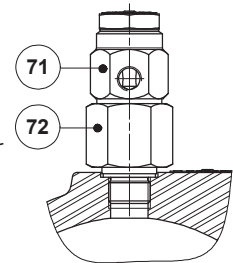
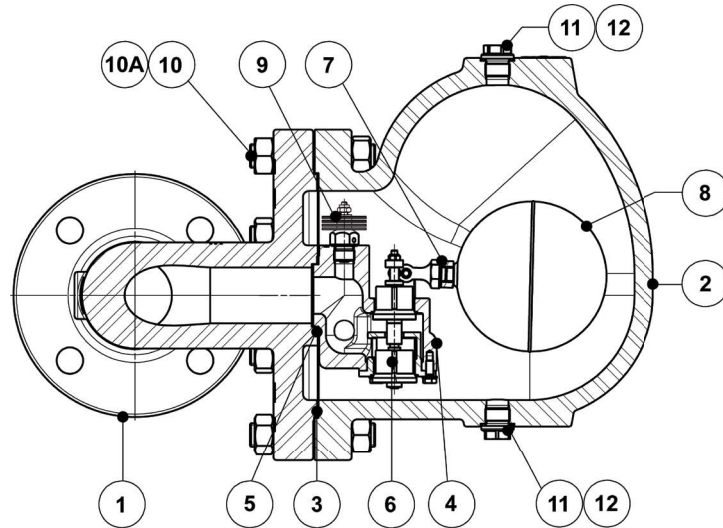

VB21M - Vacuum breaker

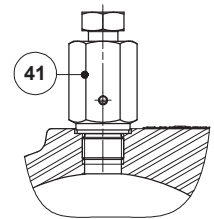

HVV - Hand vent valve

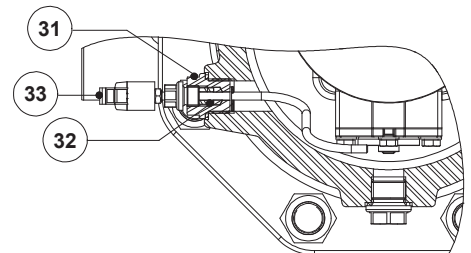

FLL - Float lifting lever

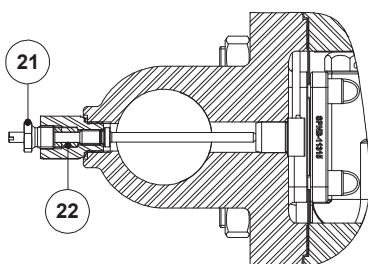

SLR - Steam lock release

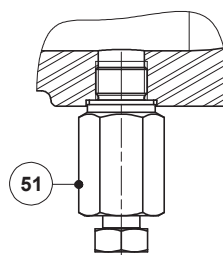

BDV - Blowdown valve
(Manual)

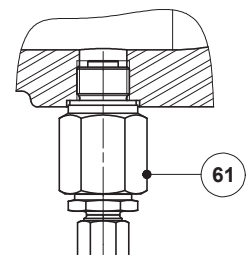

AFZ - Anti-freeze device
(Automatic)

MATERIALS		
POS. N°	DESIGNATION	MATERIAL
1	Body	A216 WCB / 1.0619
2	Cover	A216 WCB / 1.0619
3	* Gasket	Stainless steel / Graphite
4	* Seat	A351 CF8 / 1.4308; A276-98B / 1.4057
5	* Gasket	Graphite
6	* Valve	AISI 316 / 1.4401; AISI 420 / 1.4021
7	* Lever	A351 CF8M / 1.4408
8	* Float	AISI 304 / 1.4301
9	* Automatic air vent	Stainless steel (bimetallic)
10	Studs	Zinc plated steel
10A	Nuts	Zinc plated steel
11	Plug	AISI 316L / 1.4404
12	** Gasket	Copper; AISI 304 / 1.4301
21	Steam Lock Release	AISI 420 / 1.4021 AISI 316L / 1.4404
22	Packing	Graphite
31	Lever mechanism	AISI 303 / 1.4305 ; AISI 304 / 1.4301; AISI 316L / 1.4404
32	Packing	Graphite
33	Lever	Plastic
41	Hand vent valve	AISI 303 / 1.4305; AISI 316L / 1.4404
51	Blowdown valve	AISI 303 / 1.4305; AISI 316L / 1.4404
61	Anti-freeze device	AISI 303 / 1.4305; AISI 316L / 1.4404
71	Vacuum breaker	AISI 303 / 1.4305
72	Adapter fitting	AISI 303 / 1.4305

* Available spare parts; ** Not applicable in NPT version.

FLOW DIRECTION

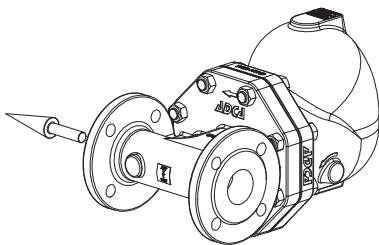

IR - Horizontal from right to left

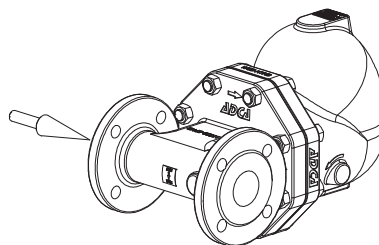

IL - Horizontal from left to right

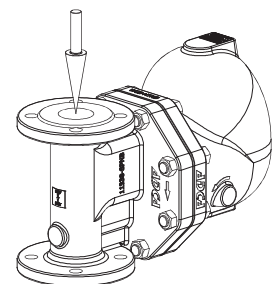

IT - Vertical from top to bottom

ORDERING CODES FLT39										
Model	A39	2	V	XX	X	X	IR	A	50	
FLT39 – A216 WCB / 1.0619 carbon steel	A39									
Differential pressure										
4,5 bar		2								
10 bar		3								
21 bar		4								
32 bar		5								
Automatic air vent										
Bimetallic air vent (standard)			V							
None			X							
Cover connections										
None				XX						
3/8" threaded connections on top and bottom, closed with plugs (mandatory if any options are considered)				10						
Options										
If any, these have specific separate ordering codes, please refer to the appropriate documentation.										
SLR - Steam lock release										
None					X					
With steam lock release assembled					S					
FLL - Float lifting lever										
None						X				
Lifting lever on the right side (when facing the steam trap body)						R				
Lifting lever on the left side (when facing the steam trap body)						L				
Flow direction										
Horizontal from right to left (standard)							IR			
Horizontal from left to right							IL			
Vertical from top to bottom							IT			
Pipe connections										
Female threaded ISO 7 Rp								A		
Female threaded NPT								C		
Socket weld ASME B16.11								H		
Flanged EN 1092-1 PN 40								N		
Flanged ASME B16.5 Class 150								U		
Flanged ASME B16.5 Class 300								V		
Size										
2" or DN 50									50	
Special valves / Extras										
Full description or additional codes have to be added in case of a non-standard combination										E