

DATA SHEET FOR ADCATROL CONTROL VALVES

VALVE SIZING

The valve sizing is based on the calculation of the Kv coefficient. The Kv represents the quantity of water, expressed in cubic meters (m³) at 15 °C, that flows through the valve with a pressure drop of 1 bar, in one hour period. The formulas, below indicated, allow the Kv calculation in accordance with the type of fluid and its operating condition.

After the Kv calculation, the corresponding Kvs is available from the valve data sheet. If real operating data have been used for the calculation, as a rule, the calculated Kv should be around 70% to 80% of the selected valve Kvs in order to ensure the proper regulation of maximum flow rate at the given operating conditions, preventing that sometimes some precautionary additions will result in undesirable valve oversizing. At the same time, it is necessary to check whether the minimum flow rate can be even regulated or not, considering the chosen valve rangeability.

For critical applications (critical flow velocities, for example), noise prediction, etc, please fill the data sheet available in the next pages and submit it to our technical department for proper selection using our software.

CALCULATION OF Kv VALUE			
PRESSURE DROP	MEDIUM		
	LIQUIDS	SATURATED STEAM	GASES
a) $P_2 > \frac{P_1}{2}$ $Dp < \frac{P_1}{2}$	$K_v = Q_1 \sqrt{\frac{d_1}{Dp \times 1000}}$	$K_v = \frac{Q_2}{22,4 \sqrt{Dp \times P_2}}$	$K_v = \frac{Q_3}{514} \sqrt{\frac{d_2 \times T}{Dp \times P_2}}$
b) $P_2 < \frac{P_1}{2}$ $Dp > \frac{P_1}{2}$		$K_v = \frac{Q_2}{11,2 \times P_1}$	$K_v = \frac{Q_3}{257 \times P_1} \sqrt{d_2 \times T}$

Remarks: For superheated steam and other fluids please consult.

a) Subcritical pressure drop: downstream absolute pressure more than 50% of the absolute upstream pressure in the valve.

b) Supercritical pressure drop: downstream absolute pressure is equal or less than 50% of the upstream absolute pressure in the valve.

Kv	Flow coefficient	m ³ /h
P1	Upstream absolute pressure	bar
P2	Downstream absolute pressure	bar
Dp	Pressure drop (P1 – P2)	bar
Q1	Flow rate	m ³ /h
Q2	Flow rate	kg/h
Q3	Flow rate	N.m ³ /h (0 °C – 1013 mbar)
d1	Specific weight of liquid	kg/m ³
d2	Specific weight of gas	kg/m ³
T	Absolute temperature (T=273 + t °C)	°K
t	Fluid temperature	°C

RECOMMENDED FLOW VELOCITIES AT THE INLET OF VALVES

LIQUIDS	GASES	SATURATED STEAM	SUPERHEATED STEAM
2,5 m/s	20 m/s	25 m/s	50 m/s

SUPERCritical PRESSURE DROP

When pressure ratio is supercritical, the flow reaches acoustic velocity at the narrowest section, causing a higher level of noise, cavitation or flashing. In these cases, the single or double perforated trim design is recommended.

INHERENT FLOW CHARACTERISTICS

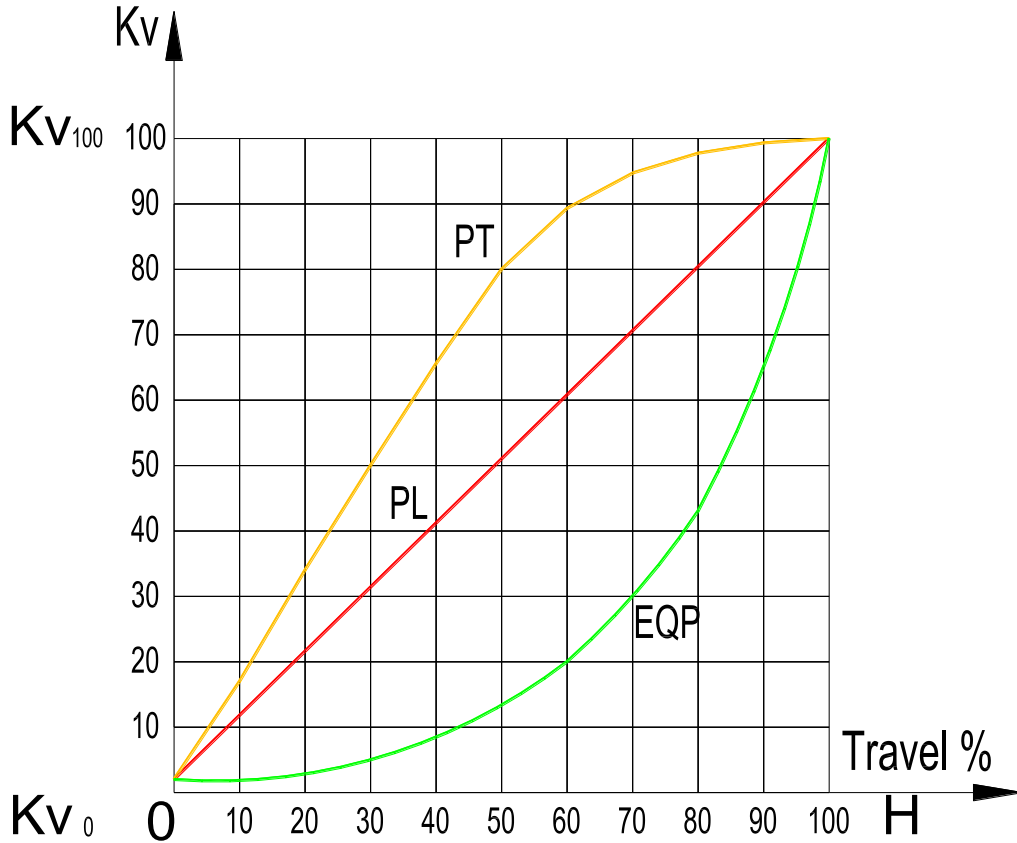

PT – On-off: the flow rate changes from 0 to 100% - fully open or fully closed control.

PL – Linear: the flow capacity or Kv increases linearly with valve travel. The flow is directly proportional to the valve travel. Recommended when there are no relevant variations in differential pressure or flow rates

EQP – Equal-percentage: for equal increments of valve plug travel, the change in flow rate related to travel may be expressed as a constant percentage of the flow rate at the time of the change. At constant differential pressure, a valve travel increase of 10% usually corresponds to a flow rate increase equal to 50% of the valve flow preceding the variation. The change in flow rate observed, related to travel, will be relatively small when the valve plug is near its seat and relatively high when the valve plug is nearly wide open. Recommended when there are wide variations in flow rate or differential pressure.

CONTROL VALVE SEAT LEAKAGE CLASSIFICATIONS					
BO – Leak test on the closure with air, in accordance with DIN 3230					
NOMINAL SIZE (DN)		LEAKAGE RATE 1	LEAKAGE RATE 2	LEAKAGE RATE 3	TEST PERIOD (minutes)
Over	Up to	Bubbles per minute a)		cm ³ per minute	
–	40	0	2	25	0,25
40	100	0	6	63	1
100	150	0	9	94	1
150	200	0	12	125	2
200	250	0	15	157	2
250	300	0	18	188	2

Kvs VALUES FOR ADCATROL V25 AND V40 – STANDARD PARABOLIC PLUGS

SEAT Ø (mm)	VALVE STROKE (mm)	SIZES											
		DN 15	DN 20	DN 25	DN 32	DN 40	DN 50	DN 65	DN 80	DN 100	DN 125	DN 150	DN 200
4 *	20	0,1	–	–	–	–	–	–	–	–	–	–	–
4 *		0,25	–	–	–	–	–	–	–	–	–	–	–
4 *		0,5	–	–	–	–	–	–	–	–	–	–	–
8 *		1	–	–	–	–	–	–	–	–	–	–	–
8 *		1,7	1,7	–	–	–	–	–	–	–	–	–	–
12		2,1	2,5	3	–	–	–	–	–	–	–	–	–
12		2,7	3,7	4	4,3	–	–	–	–	–	–	–	–
15		3,8	4,7	5,8	6,1	6,8	–	–	–	–	–	–	–
20		–	5,1	6,3	7,8	9,3	10,2	–	–	–	–	–	–
25		–	–	9,4	11,7	14,6	17,5	18,7	–	–	–	–	–
32		–	–	–	15,4	19,2	24	28	30,5	–	–	–	–
40		–	–	–	–	22,2	27,7	34,6	40,8	44,7	–	–	–
50		–	–	–	–	–	40,1	49	61	68	74,1	–	–
65		30 / 40	–	–	–	–	–	63,4	79,2	91	109,3	119	–
80			–	–	–	–	–	–	89,7	112,1	139,8	166	182
100	–		–	–	–	–	–	–	136,7	170,8	212,5	243	
125	40 / 50	–	–	–	–	–	–	–	–	230,6	288,2	359,4	
150		–	–	–	–	–	–	–	–	–	316,1	396	
200	50 / 80	–	–	–	–	–	–	–	–	–	–	590	

* Microflow only available with contoured linear characteristic.

Kvs VALUES FOR ADCATROL V25 AND V40 – PERFORATED PLUG PL (LINEAR)

SEAT Ø (mm)	VALVE STROKE (mm)	SIZES											
		DN 15	DN 20	DN 25	DN 32	DN 40	DN 50	DN 65	DN 80	DN 100	DN 125	DN 150	DN 200
15	25	2,55	2,65	2,65	2,65	2,65	–	–	–	–	–	–	–
20		–	4,6	4,8	4,8	4,8	4,8	–	–	–	–	–	–
25		–	–	7,1	7,5	7,5	7,5	7,5	–	–	–	–	–
32	30	–	–	–	11,8	11,8	11,8	11,8	11,8	–	–	–	–
40		–	–	–	–	18	18	18	19	19	–	–	–
50		–	–	–	–	–	28	30	30	30	30	–	–
65	40	–	–	–	–	–	–	48	50	50	50	50	–
80	50	–	–	–	–	–	–	–	74	75	75	76	76
100		–	–	–	–	–	–	–	–	115	121	121	121
125	60	–	–	–	–	–	–	–	–	–	180	189	189
150	80	–	–	–	–	–	–	–	–	–	–	260	270
200		–	–	–	–	–	–	–	–	–	–	–	402

Kvs VALUES FOR ADCATROL V25 AND V40 – PERFORATED PLUG EQP (EQUAL PERCENTAGE)

SEAT Ø (mm)	VALVE STROKE (mm)	SIZES											
		DN 15	DN 20	DN 25	DN 32	DN 40	DN 50	DN 65	DN 80	DN 100	DN 125	DN 150	DN 200
15	25	–	–	–	–	–	–	–	–	–	–	–	–
20		–	2,65	2,65	2,65	2,65	–	–	–	–	–	–	–
25		–	–	4,8	4,8	4,8	4,8	–	–	–	–	–	–
32	30	–	–	–	7,5	7,5	7,5	7,5					
40		–	–	–		11,8	11,8	11,8	11,8				
50		–	–	–			18	18	19	19			
65	40	–	–	–				30	30	30	30		
80	50	–	–	–					50	50	50	50	
100		–	–	–						75	75	76	76
125	60	–	–	–							121	121	121
150	80	–	–	–								189	189
200		–	–	–									270

ADCATROL – DETAILS FOR SELECTION AND SIZING

CUSTOMER:	OUR REF ^a
VALVE TYPE:	REG NR.: DATE: / / PAGE: /

1		SERVICE :							
2		PIPELINE SIZE / RATING :	DN	PN.....	CLASS				
3		FLUID :	STATE AT THE INPUT :	<input type="checkbox"/> LIQUID	<input type="checkbox"/> STEAM	<input type="checkbox"/> GAS			
4		VISCOSITY :	cP	TEMP.: °C	SPECIF. WEIGHT :	<input type="checkbox"/> Kgs/dm3	<input type="checkbox"/> Kg/Nm3		
5	OPERATING CONDITIONS	FLOW RATE :			MIN.	STAND.	MAX.		
6		UPSTREAM PRESSURE ABS.(Gauge + Atmospheric press.) :							
7		DOWNSTREAM PRESSURE ABS.(Gauge + Atmospheric press.) :							
8		PRESSURE DROP (bar) :							
9		AMBIENT TEMPERATURE °C :							
10			VALVE TYPE:	<input type="checkbox"/> 2 way	<input type="checkbox"/> Straightway	<input type="checkbox"/> Angle valve	Fluid Direction:	<input type="checkbox"/> under	<input type="checkbox"/> over (the seat)
11				<input type="checkbox"/> 3 way	<input type="checkbox"/> Mixing	AB ← A	<input type="checkbox"/> Diverging	AB → A	
12			ACTION ON FAILURE:	AB ←	<input type="checkbox"/>	B	AB →	<input type="checkbox"/>	B
13		VALVE BODY	TAG:						
14	SIZE / RATING:		DN	PN.....	CLASS				
15	TYPE OF CONNECTION:		<input type="checkbox"/> Flanged	<input type="checkbox"/> EN	<input type="checkbox"/> ANSI	<input type="checkbox"/> Threader	<input type="checkbox"/> Welded end	<input type="checkbox"/>	
16	BODY MATERIAL:								
17	PLUG MATERIAL:		<input type="checkbox"/> Stainless steel	<input type="checkbox"/> Soft	<input type="checkbox"/> Stellite	<input type="checkbox"/>			
18	SOFT SEAT SEAL MATERIAL:		<input type="checkbox"/> PTFE / GR	<input type="checkbox"/> PTFE	<input type="checkbox"/>				
19	PLUG CHARACTERISTICS:		<input type="checkbox"/> Equal %	<input type="checkbox"/> Linear	<input type="checkbox"/> On / Off				
20	SEAL:		<input type="checkbox"/> Metal	<input type="checkbox"/> Soft	<input type="checkbox"/> CLASSE				
21	SEAT MATERIAL:		<input type="checkbox"/> Stainless steel	<input type="checkbox"/> Stellite	<input type="checkbox"/>				
22	REDUCE BORE:		<input type="checkbox"/> Yes	<input type="checkbox"/> No	Size				
23	BONNET:	<input type="checkbox"/> Standard	<input type="checkbox"/> Finned	<input type="checkbox"/> Extended	<input type="checkbox"/>				
24	STUFFING BOX PACKING:	<input type="checkbox"/> Virgin PTFE	<input type="checkbox"/> PTFE / GR	<input type="checkbox"/> Pure Graphite	<input type="checkbox"/> Bellows	<input type="checkbox"/> Other	Number _____		
25	ACTUATOR	ACTUATOR REF.:	<input type="checkbox"/> Pneumatic	<input type="checkbox"/> Electric	<input type="checkbox"/> Manual	<input type="checkbox"/>			
26		PNEUMATIC SIGNAL:	<input type="checkbox"/> 0,2 - 1 bar	<input type="checkbox"/> 0,4 - 1,2 bar	<input type="checkbox"/> 0,4 - 2 bar	<input type="checkbox"/> 0 - 2,5 bar	<input type="checkbox"/>		
27		ACTION ON AIR FAILURE:	<input type="checkbox"/> Closed	<input type="checkbox"/> Opened	HANDWHEEL:	<input type="checkbox"/> Yes	<input type="checkbox"/> No		
28		ELECTRIC SIGNAL:	<input type="checkbox"/> 4-20 mA	<input type="checkbox"/> 0-10 V	<input type="checkbox"/>	INITIAL COMPRESSION mm		
29		ACTION ON CURRENT FAILURE:	<input type="checkbox"/> Closed	<input type="checkbox"/> Opened	<input type="checkbox"/> Stop				
30	ELECTRIC SUPPLY:	<input type="checkbox"/> 230 V	<input type="checkbox"/> 24 V	<input type="checkbox"/>					
31	LIMIT SWITCHES:	<input type="checkbox"/> Open valve limit switch	<input type="checkbox"/> Close valve limit switch						
32	POSITIONER	POSITIONER REF:	<input type="checkbox"/> Pneumatic	<input type="checkbox"/> Electro - pneumatic	<input type="checkbox"/> Electric				
33		CONTROL SIGNAL:	<input type="checkbox"/> Pneumatic	<input type="checkbox"/> Electric					
34		CONTROL VALVE: Opened at:	psi/bar mAV	Closed at:	psi/bar mA	
35		AIR FILTER REGULATOR:	<input type="checkbox"/> Yes	<input type="checkbox"/> No	AIR SUPPLY:	psi / bar			
36	SOLENOID VALVE:	<input type="checkbox"/> Yes	<input type="checkbox"/> No	<input type="checkbox"/> ... VAC	<input type="checkbox"/> ... VDC				

REMARKS: _____

ADCATROL CONTROL VALVES General Information

TWO WAY VALVES

Application:
 On/off, control of flow, pressure and temperature.

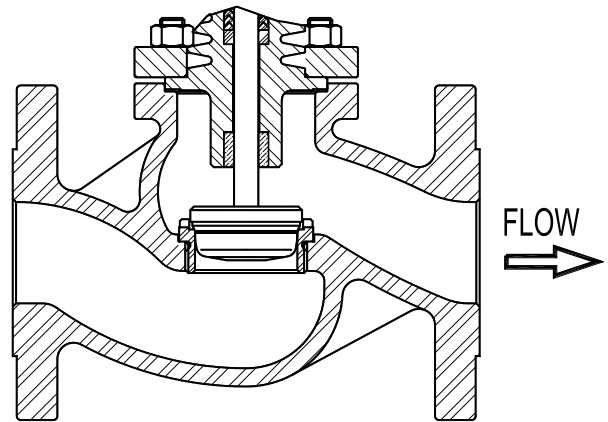

Fig.1

THREE WAY MIXING VALVES

Application:
 Mixing of two streams
 By-pass at heat exchangers

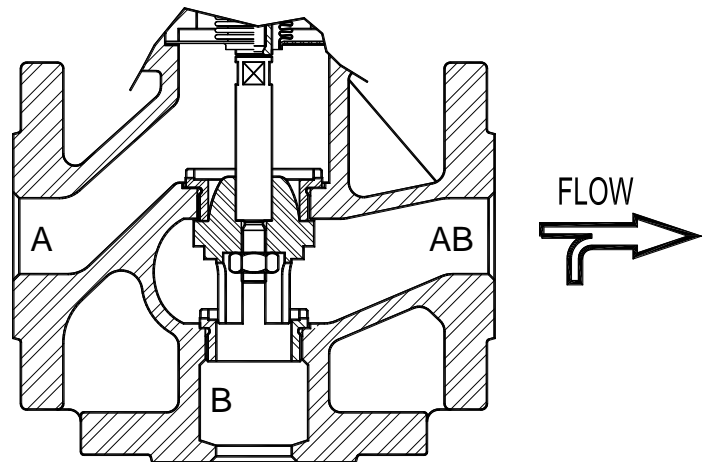

Fig.2

THREE WAY DIVERTING VALVES

Application:
 Diverting of two streams
 By-pass at heat exchangers *
 Diverting into two different systems
 (* The mixing design is recommended, see Fig.6)

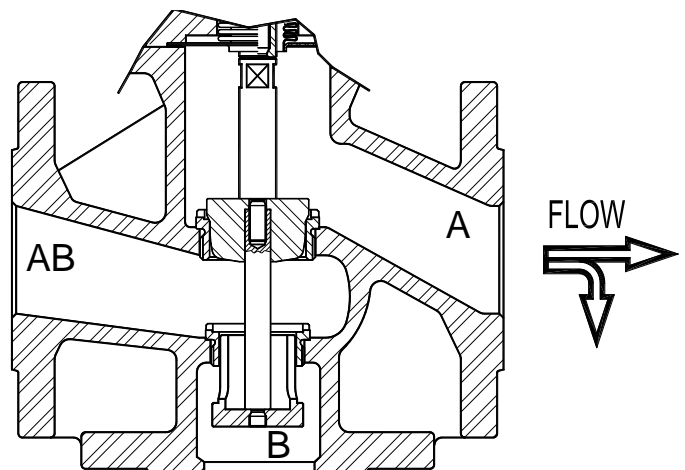
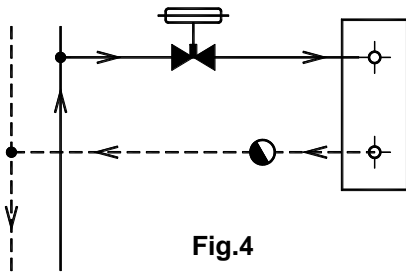

Fig.3

TYPICAL REGULATION LOOPS



Two-way valve arrangement
 Fluid: saturated steam

Fig.4

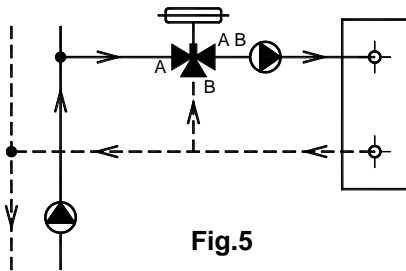

Three – way mixing valve arrangement
 (mixing regulation)
 Fluids: water, diathermic oil, ...

Fig.5

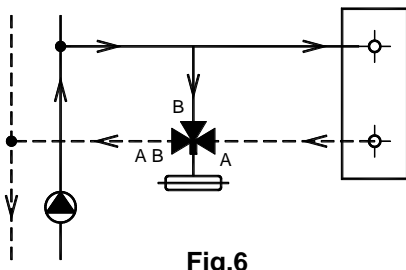

Three – way mixing valve arrangement
 (diverting regulation)
 Fluids: water, diathermic oil, ...

Fig.6

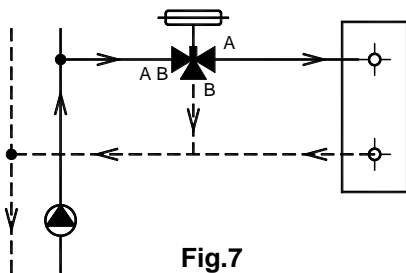

Three – way diverting valve arrangement
 Fluids: water, diathermic oil, ...

Fig.7

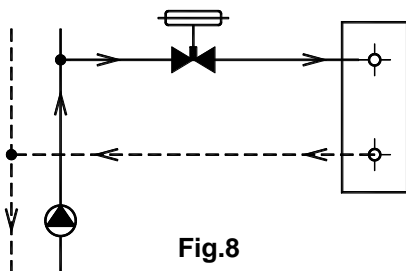

Two-way valve arrangement
 Fluids: water, diathermic oil, ...

Fig.8

ADCATROL - VALVE PLUGS

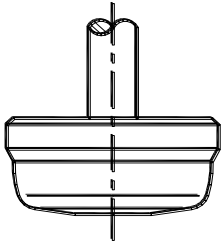

PARABOLIC PLUG (two-way valve)
 Characteristic: linear or equal percentage
 Flow direction: from below
 Ratio: 30:1 to 50:1
 Material: stainless steel
 Sealing: metal to metal
 Leakage: class IV
 acc. IEC 60534-4:2006
 Application: steam, water and other fluids and gases without cavitation.

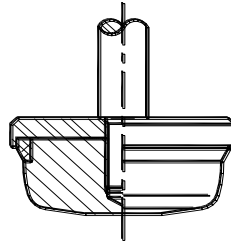

PARABOLIC PLUG (two-way valve)
 Characteristic: linear or equal percentage
 Flow direction: from below
 Ratio: 30:1 to 50:1
 Material: stainless steel
 Sealing: soft sealing-PTFE/Graphite
 Leakage: class V
 acc. IEC 60534-4:2006
 Application: Steam, water and other fluids and gases up to 200°C without cavitation.

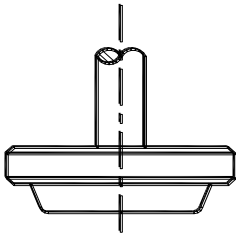

ON/OFF PLUG (two-way valve)
 Characteristic: none
 Flow direction: from below or above
 Material: stainless steel
 Sealing: metal to metal
 Leakage: class IV
 acc. IEC 60534-4:2006
 Application: shut off of all media

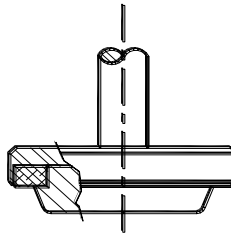

ON/OFF PLUG (two-way valve)
 Characteristic: none
 Flow direction: from below or above
 Material: stainless steel
 Sealing: soft sealing-PTFE/Graphite
 Leakage: class V
 acc. IEC 60534-4:2006
 Application: shut off of all media up to 200°C

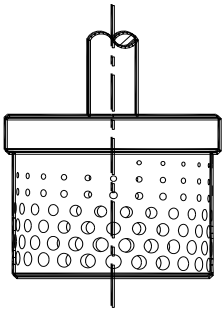

PERFORATED PLUG (two-way valve)
 Characteristic: linear or equal percentage
 Flow direction: from above
 Ratio: 30:1 to 40:1
 Material: stainless steel
 Sealing: metal to metal
 Leakage: class IV
 acc. IEC 60534-4:2006
 Application: steam, water and other fluids and gases. Can be use where cavitation and flashing is present and if noise reduction is required.

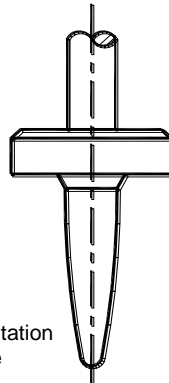

MICROFLOW PLUG (two-way valve)
 Characteristic: linear or equal percentage
 Flow direction: from below
 Ratio: 50:1
 Material: stainless steel
 Sealing: metal to metal
 Leakage: class IV
 acc. IEC 60534-4:2006
 Application: steam, water and other fluids and gases where extremely low flow rates are present.

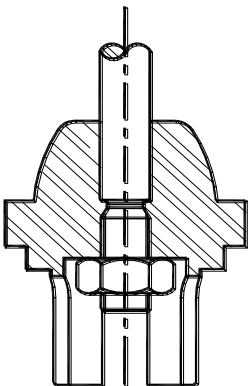

MIXING PLUG (three-way valve)
 Characteristic: linear/linear
 Ratio: 30:1 to 50:1
 Material: stainless steel
 Sealing: metal to metal
 Leakage: class IV
 acc. IEC 60534-4:2006
 Application: Water, diathermic oil, ...

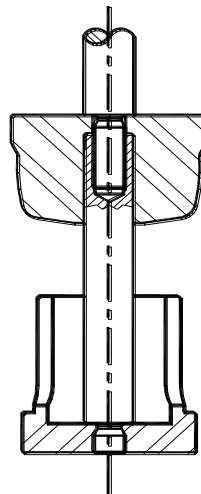

DIVERTING PLUG (three-way valve)
 Characteristic: linear /linear
 Ratio: 30:1
 Material: stainless steel
 Sealing: metal to metal
 Leakage: class IV
 acc. IEC 60534-4:2006
 Application: Water, diathermic oil, ...

ADCATROL SPINDLE PACKING

“V” RINGS WITH SPRING

Type: V1.1
 Max. pressure: 40bar
 Max. temperature: 200°C
 Material: PTFE/Graphite
 Application: Steam, water and other fluids

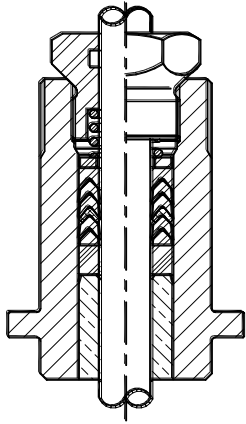

GRAPHITE

Type: G1
 Max. pressure: 40bar
 Max. temperature: 400°C
 Material: Graphite
 Application: Steam, water and other fluids

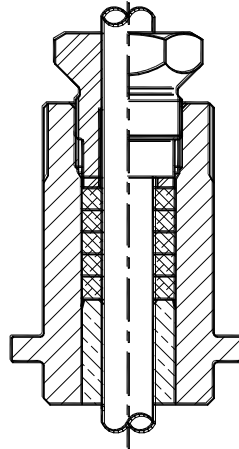

“V” RINGS WITH SPRING

Type: V2.1
 Max. pressure : 40bar
 Max. temperature: 180°C
 Material: PTFE
 Application: Steam, water and other fluids

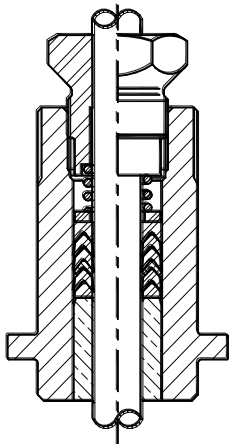

“V” RINGS W/SPRING & COOLING FINS

Type: V1.1 and VV1.1
 Max. pressure : 40bar
 Max. temperature: 250°C
 Material: PTFE/Graphite
 Application: Steam, water and other fluids

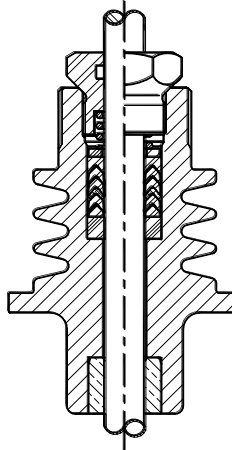

BELLOWS

Max. pressure : 25bar
 Max. temperature: 400°C
 Material: Stainless steel
 Application: Water, diathermic oil,...

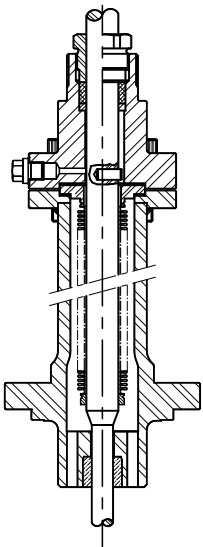

“V” RINGS WITH SPRINGS

Type: VV1.1
 Max. pressure : 40bar
 Max. temperature: 200°C
 Material: PTFE/Graphite
 Application: Steam, water and other fluids

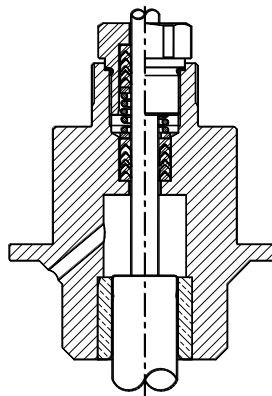

PHYSICAL PROPERTIES OF SATURATED STEAM

Pm (bar)	Pa (bar)	T (°C)	V (m ³ /kg)	he (kcal/kg)	he (kJ/kg)	r (kcal/kg)	r (kJ/kg)	Hg (kcal/kg)	Hg (kJ/kg)
0,00	1,013	100,0	1,673	100,1	419,1	539,4	2258,4	639,5	2677,5
0,05	1,063	101,4	1,601	101,5	425,0	538,4	2254,2	639,9	2679,1
0,10	1,113	102,6	1,533	102,8	430,4	537,7	2251,2	640,5	2681,6
0,15	1,163	105,1	1,471	104,1	435,8	536,9	2247,9	641,0	2683,7
0,20	1,213	106,2	1,414	105,3	440,9	536,2	2245,0	641,5	2685,8
0,30	1,313	107,4	1,312	107,6	450,5	534,7	2238,7	642,3	2689,2
0,40	1,413	109,5	1,225	109,8	459,7	533,3	2232,8	643,1	2692,5
0,50	1,513	111,6	1,149	111,9	468,5	531,9	2227,0	643,8	2695,5
0,60	1,613	113,5	1,038	113,8	476,5	530,6	2221,5	644,4	2698,0
0,70	1,713	115,4	1,024	115,7	484,4	529,5	2216,9	645,2	2701,3
0,80	1,813	117,1	0,971	117,5	491,9	528,3	2211,9	645,8	2703,8
0,90	1,913	118,8	0,923	119,2	499,1	527,1	2206,9	646,3	2705,9
1,00	2,013	120,4	0,881	120,8	505,8	526,0	2202,3	646,8	2708,0
1,10	2,113	121,9	0,841	122,4	512,5	525,1	2198,5	647,5	2711,0
1,20	2,213	123,4	0,806	124,0	519,2	524,1	2194,3	648,1	2713,5
1,30	2,313	124,9	0,773	125,4	525,0	523,1	2190,1	648,5	2715,1
1,40	2,413	126,3	0,743	126,8	530,9	522,2	2186,3	649,0	2717,2
1,50	2,513	127,6	0,714	128,1	536,3	521,1	2181,7	649,2	2718,1
1,60	2,613	128,9	0,689	129,5	542,2	520,4	2178,8	649,9	2721,0
1,70	2,713	130,1	0,665	130,7	547,2	519,5	2175,0	650,2	2722,3
1,80	2,813	131,4	0,643	132,0	552,7	518,6	2171,3	650,6	2723,9
1,90	2,913	132,5	0,622	133,2	557,7	517,8	2167,9	651,0	2725,6
2,00	3,013	133,7	0,603	134,4	562,7	517,0	2164,6	651,4	2727,3
2,20	3,213	135,9	0,568	136,6	571,9	515,5	2158,3	652,1	2730,2
2,40	3,413	138,0	0,536	138,8	581,1	514,0	2152,0	652,8	2733,1
2,60	3,613	140,0	0,509	140,8	589,5	512,6	2146,2	653,4	2735,7
2,80	3,813	141,9	0,483	142,8	597,9	511,2	2140,3	654,0	2738,2
3,00	4,013	143,7	0,461	144,7	605,8	509,9	2134,8	654,6	2740,7
3,20	4,213	145,4	0,440	146,4	612,9	508,6	2129,4	655,0	2742,4
3,40	4,413	147,2	0,422	148,2	620,5	507,4	2124,4	655,6	2744,9
3,60	4,613	148,8	0,405	149,9	627,6	506,1	2118,9	656,0	2746,5
3,80	4,813	150,4	0,389	151,5	634,3	505,0	2114,3	656,5	2748,6
4,00	5,013	152,0	0,374	153,1	641,0	503,8	2109,3	656,9	2750,3
4,20	5,213	153,4	0,361	154,6	647,3	502,7	2104,7	657,3	2752,0
4,40	5,413	154,8	0,348	156,1	653,6	501,6	2100,1	657,7	2753,7
4,60	5,613	156,2	0,336	157,6	659,8	500,6	2095,9	658,2	2755,8
4,80	5,813	157,6	0,325	159,0	665,7	499,5	2091,3	658,5	2757,0
5,00	6,013	158,9	0,315	160,3	671,1	498,5	2087,1	658,8	2758,3
5,50	6,513	162,1	0,292	163,6	685,0	496,1	2077,1	659,7	2762,0
6,00	7,013	165,0	0,272	166,7	697,9	493,8	2067,4	660,5	2765,4
6,50	7,513	167,8	0,255	169,6	710,1	491,6	2058,2	661,2	2768,3
7,00	8,013	170,5	0,240	172,4	721,8	489,4	2049,0	661,8	2770,8
7,50	8,513	173,0	0,227	175,1	733,1	487,4	2040,6	662,5	2773,8
8,00	9,013	175,4	0,215	177,6	743,6	485,4	2032,3	663,0	2775,8
8,50	9,513	177,7	0,204	180,0	753,6	483,5	2024,3	663,5	2777,9
9,00	10,013	180,0	0,194	182,3	763,3	481,6	2016,4	663,9	2779,6
9,50	10,513	182,1	0,185	184,6	772,9	479,8	2008,8	664,4	2781,7
10,00	11,013	184,1	0,177	186,8	782,1	478,0	2001,3	664,8	2783,4
11,00	12,013	188,0	0,163	190,9	799,3	474,6	1987,1	665,5	2786,3
12,00	13,013	191,7	0,151	194,8	815,6	471,4	1973,7	666,2	2789,2
13,00	14,013	195,1	0,141	198,5	831,1	468,3	1960,7	666,8	2791,8
14,00	15,013	198,3	0,132	202,0	845,7	465,3	1948,1	667,3	2793,9
15,00	16,013	201,4	0,124	205,3	859,6	462,5	1936,4	667,8	2795,9
16,00	17,013	204,4	0,117	208,5	872,9	459,7	1924,7	668,2	2797,6
17,00	18,013	207,2	0,110	211,5	885,5	457,0	1913,4	668,5	2798,9
18,00	19,013	209,9	0,105	214,4	897,8	454,4	1902,5	668,8	2800,1
19,00	20,013	212,5	0,100	217,2	909,4	451,8	1891,6	669,0	2801,0
20,00	21,013	215,0	0,095	220,0	921,1	449,4	1881,5	669,4	2802,6
21,00	22,013	217,3	0,090	222,6	932,0	447,0	1871,5	669,6	2803,5
22,00	23,013	219,6	0,087	225,1	942,4	444,6	1861,5	669,7	2803,9
23,00	24,013	221,8	0,083	227,6	952,9	442,2	1851,4	669,8	2804,3
24,00	25,013	224,0	0,080	230,0	963,0	440,0	1842,2	670,0	2805,2
25,00	26,013	226,1	0,077	232,3	972,6	437,7	1832,6	670,0	2805,2

Pm – gauge pressure; Pa – absolute pressure; T – temperature; V – specific volume; he – specific enthalpy of liquid; r – specific enthalpy of vaporization; Hg – specific enthalpy of saturated steam.

MASS FLOWRATES OF SATURATED STEAM FOR DIFFERENT VELOCITIES IN PIPES DIN2448 – STANDARD

Pm bar	v m/s	FLOWRATE (kg/h)													
		DN 15	DN 20	DN 25	DN 32	DN 40	DN 50	DN 65	DN 80	DN 100	DN 125	DN 150	DN 200	DN 250	DN 300
0.4	15	10	17	28	48	64	103	171	236	397	600	878	1476	2346	3319
	25	17	29	47	80	107	171	285	393	662	1000	1464	2459	3911	5532
	40	28	46	75	128	171	274	456	628	1058	1601	2342	3935	6257	8851
0.6	15	12	20	33	56	76	121	202	278	468	708	1036	1741	2769	3917
	25	20	34	55	94	126	202	336	463	781	1181	1727	2902	4615	6528
	40	33	54	89	151	202	324	538	741	1249	1889	2764	4644	7384	10445
0.8	15	13	22	35	60	81	130	216	297	501	757	1108	1862	2960	4187
	25	22	36	59	101	135	216	360	495	835	1262	1846	3103	4934	6979
	40	35	58	95	161	216	346	575	792	1335	2019	2954	4964	7894	11166
1	15	14	24	39	67	89	143	238	327	552	835	1221	2052	3263	4615
	25	24	40	65	111	149	238	396	546	920	1391	2035	3420	5438	7692
	40	38	64	104	178	238	381	634	873	1472	2226	3256	5471	8700	12307
1.5	15	18	29	48	82	110	176	293	404	681	1030	1507	2532	4026	5694
	25	30	49	80	137	184	294	489	673	1135	1716	2511	4219	6710	9491
	40	47	79	129	219	294	470	783	1078/	1816	2746	4018	6751	10735	15185
2	15	21	35	57	97	131	209	347	478	806	1219	1784	2998	4767	6743
	25	35	58	95	162	218	348	579	797	1344	2032	2973	4996	7945	11238
	40	56	93	152	259	348	557	927	1276	2150	3252	4757	7994	12711	17980
2.5	15	24	40	66	112	151	241	401	553	931	1409	2061	3463	5506	7789
	25	41	67	110	187	251	402	669	921	1552	2348	3435	5771	9177	12982
	40	65	108	176	300	402	643	1070	1474	2484	3756	5495	9234	14684	20770
3	15	28	46	75	127	171	273	454	626	1055	1595	2333	3921	6235	8820
	25	46	76	125	212	285	455	757	1043	1758	2658	3889	6535	10392	14699
	40	73	122	199	339	455	728	1212	1669	2813	4253	6223	10456	16627	23519
4	15	34	56	92	157	211	337	560	771	1300	1966	2876	4833	7685	10871
	25	57	94	154	261	351	561	934	1286	2167	3277	4794	8055	12809	18119
	40	90	150	246	418	561	898	1494	2057	3467	5243	7670	12888	20495	28990
5	15	40	67	109	186	250	400	665	916	1544	2334	3415	5738	9125	12907
	25	67	111	182	310	417	666	1109	1527	2573	3890	5692	9564	15208	21512
	40	107	178	292	496	667	1066	1774	2443	4116	6224	9107	15302	24333	34420
6	15	47	77	127	216	289	463	770	1061	1788	2703	3955	6646	10568	14948
	25	78	129	211	359	482	772	1284	1768	2979	4505	6592	11076	17613	24913
	40	124	206	338	575	772	1235	2054	2829	4767	7208	10546	17722	28180	39861
7	15	53	88	144	244	328	525	873	1202	2026	3064	4482	7532	11977	16941
	25	88	146	239	407	547	875	1455	2004	3377	5106	7470	12553	19961	28235
	40	141	234	383	652	875	1399	2328	3206	5402	8170	11953	20084	31937	45176
8	15	59	98	160	273	366	586	975	1342	2261	3420	5003	8407	13369	18911
	25	98	163	267	455	610	976	1624	2237	3769	5700	8339	14012	22282	31518
	40	157	261	427	727	977	1562	2599	3579	6031	9120	13342	22420	35651	50429
9	15	65	109	178	302	406	649	1080	1487	2506	3790	5545	9318	14816	20958
	25	109	181	296	504	676	1082	1800	2479	4177	6317	9242	15529	24694	34930
	40	174	289	474	806	1082	1731	2880	3966	6683	10107	14787	24847	39510	55888
10	15	72	119	195	331	445	711	1184	1630	2747	4154	6078	10212	16239	22971
	25	119	198	324	552	741	1186	1973	2717	4578/	6923	10129	17021	27066	38285
	40	191	317	519	884	1186	1897	3157	4347	7325	11077	16207	27233	43305	61255
12	15	84	139	228	388	521	834	1388	1911	3220	4869	7124	11971	19036	26926
	25	140	232	380	647	869	1390	2313	3185	5367	8115	11873	19951	31726	44877
	40	224	372	608	1036	1390	2224	3700	5095	8587	12985	18998	31922	50761	71803
14	15	96	160	261	444	596	954	1587	2186	3683	5570	8150	13694	21776	30802
	25	160	266	435	740	994	1590	2645	3643	6139	9284	13583	22823	36293	51336
	40	256	425	696	1185	1591	2544	4233	5829	9823	14854	21732	36517	58068	82138
16	15	108	180	294	501	673	1076	1791	2466	4156	6284	9194	15450	24567	34751
	25	181	300	491	835	1122	1794	2985	4110	6926	10474	15324	25749	40945	57918
	40	289	480	785	1337	1794	2870	4775	6576	11082	16758	24518	41199	65513	92668
18	15	121	201	328	559	750	1199	1995	2748	4631	7003	10245	17215	27375	38722
	25	201	334	547	931	1250	1999	3326	4580	7718	11671	17075	28692	45625	64537
	40	322	535	875	1489	2000	3198	5321	7328	12348	18673	27320	45907	73000	103259
20	15	134	222	363	617	829	1326	2205	3037	5118	7740	11324	19027	30256	42798
	25	223	369	604	1029	1381	2209	3676	5062	8530	12899	18873	31712	50427	71330
	40	356	591	967	1646	2210	3535	5881	8099	13648	20639	30196	50740	80684	114128

VAPOUR TENSION OF WATER

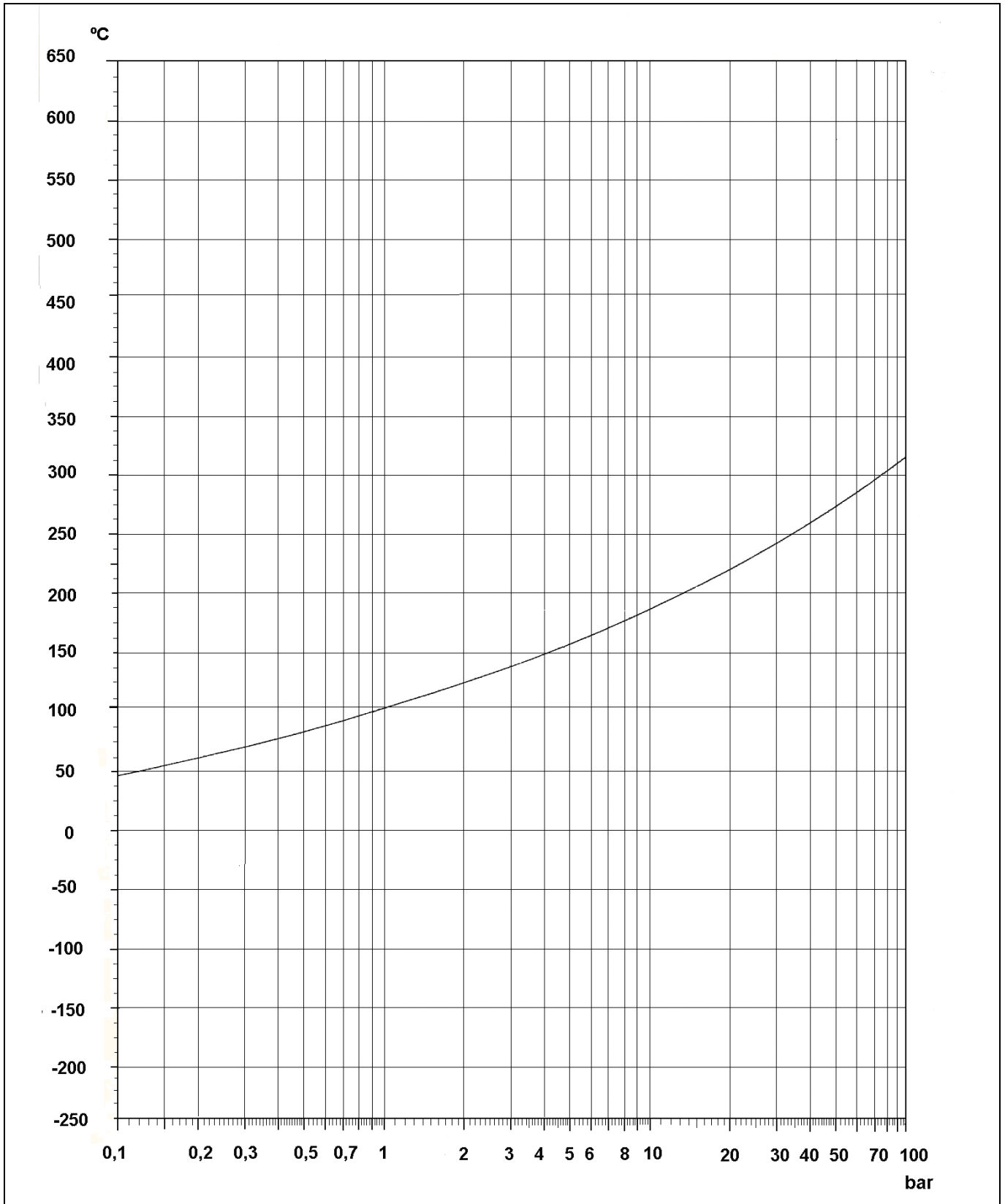

CONVERSION FACTORS

FLOW RATE IN VOLUME

UNIT		m ³ /s	L/s	cfm	gpm
<i>Cubic metre per second</i>	m ³ /s	1	1×10 ³	2118,88	15850
<i>Litre per second</i>	L/s	1×10 ⁻³	1	2,1189	15,85
<i>Cubic foot per minute</i>	cfm	0,4719×10 ⁻³	0,4719	1	7,48
<i>Gallon per minute</i>	gpm	0,6309×10 ⁻⁴	0,06309	0,1337	1

MASS

UNIT		kg	lb	ton
<i>Kilogramme</i>	kg	1	2,2046	1×10 ⁻³
<i>Pound</i>	lb	0,4536	1	0,454×10 ⁻³
<i>Ton short (US)</i>	ton	907,1847	2000	1

AREA

UNIT		m ²	cm ²	in ²	ft ²
<i>Square metre</i>	m ²	1	1×10 ⁴	1550	10,764
<i>Square centimetre</i>	cm ²	1×10 ⁻⁴	1	0,155	10,764×10 ⁻⁴
<i>Square inch</i>	in ²	6,452×10 ⁻⁴	6,452	1	6,944×10 ⁻³
<i>Square foot</i>	ft ²	9,290×10 ⁻²	928,03	144	1

LENGTH

UNIT		m	cm	mm	in	ft
<i>Metre</i>	m	1	1×10 ²	1×10 ³	39,370	3,281
<i>Centimetre</i>	cm	1×10 ⁻²	1	10	0,390	0,033
<i>Milimetre</i>	mm	1×10 ⁻³	1×10 ⁻¹	1	0,039	3,28×10 ⁻³
<i>Inch</i>	in	2,54×10 ⁻²	2,540	25,4	1	0,083
<i>Foot</i>	ft	0,305	30,480	304,8	12	1

VOLUME

UNIT		m ³	L	in ³	ft ³	gal
<i>Cubic metre</i>	m ³	1	1×10 ³	61,024×10 ³	35,315	219,969
<i>Cubic decimetre or litre</i>	dm ³ (L)	1×10 ⁻³	1	61,024	0,353	0,220
<i>Cubic inch</i>	in ³	0,0164×10 ⁻³	0,016	1	5,787×10 ⁻⁴	3,605×10 ⁻³
<i>Cubic foot</i>	ft ³	0,028	28,317	1728	1	6,229
<i>Gallon (UK)</i>	gal	4,546×10 ⁻³	4,546	277,419	0,161	1

WORK, ENERGY, HEAT AND ENTHALPY

UNIT		J	kgfm	kcal	Wh	Btu
<i>Joule</i>	J	1	0,1020	0,2388×10 ⁻³	0,2778×10 ⁻³	0,9478×10 ⁻³
<i>Kilogramme metre</i>	kgfm	9,807	1	2,342×10 ⁻³	2,724×10 ⁻³	9,295×10 ⁻³
<i>Kilocalorie</i>	kcal	4186,8	426,92	1	3,968	3,968
<i>Watt hour</i>	Wh	3600	367,08	0,861	1	3,413
<i>British thermal unit</i>	Btu	1055,06	107,58	0,252	0,293	1

POWER

UNIT		W	kcal/h	kgm/s	BTU/h	ft lb/s	BHP	CV
<i>Watt</i>	W	1	0,8605	0,102	3,413	0,7375	1,341×10 ⁻³	1,360×10 ⁻³
<i>Kilocalorie/hour</i>	kcal/h	1,1628	1	0,1186	3,9683	0,8576	1,559×10 ⁻³	1,581×10 ⁻³
<i>Kilogramme metre/sec</i>	kgm/s	9,807	8,434	1	33,47	7,233	1,315×10 ⁻²	1,333×10 ⁻²
<i>British thermal unit/hour</i>	BTU/h	0,293	0,252	0,02988	1	0,2161	0,393×10 ⁻³	0,398×10 ⁻³
<i>Foot pound/second</i>	ft lb/s	1,356	1,166	0,1383	4,627	1	1,818×10 ⁻³	1,844×10 ⁻³
<i>Brake horsepower</i>	BHP	745,7	641,3	76,04	2547	550	1	1,0139
<i>Horsepower (metric)</i>	CV	735,5	632,53	75	2512,2	542,4	0,986	1

VELOCITY

UNIT		m/s	ft/s	km/h
<i>Metre per second</i>	m/s	1	3,2808	3,6
<i>Foot per second</i>	ft/s	0,3048	1	1,0973
<i>Kilometre per hour</i>	km/h	0,2778	0,9113	1

PRESSURE

UNIT		Pa	bar	at	mm Hg	kgf/m ²	psi	lbf/ft ²
<i>Pascal</i>	Pa	1	1×10 ⁻⁵	1,0197×10 ⁻⁵	0,0075	0,10197	0,145×10 ⁻³	0,02088
<i>Bar</i>	bar	1×10 ⁵	1	1,0197	750,07	10197	14,5050	2088
<i>Atmosphere (Kgf/cm²)</i>	atm	98070	0,9807	1	735,56	10000	14,223	2048,16
<i>Millimetre of mercury</i>	mm Hg	133,32	1,3332×10 ⁻³	1,3595×10 ⁻³	1	13,595	0,0193	1,392
<i>Kilogramme per sq. mtr.</i>	kgf/m ²	9,807	9,807×10 ⁻⁵	1×10 ⁻⁴	0,0735	1	0,0014	0,205
<i>Pounds per sq. Inch</i>	psi	6894,14	0,06894	0,0703	51,719	703,07	1	144
<i>Pounds per sq. foot</i>	lbf/ft ²	47,876	4,7876×10 ⁻⁴	4,8824×10 ⁻⁴	0,7183	4,8824	0,00694	1

WATER HARDNESS

UNIT		°Fr	°dH	GPG	ppm
<i>French degree</i>	°Fr	1	0,56	0,583	10,0
<i>German degree</i>	°dH	1,79	1	1,040	17,9
<i>Grain/US gallon</i>	GPG	1,71	0,958	1	17,1
<i>Parts per million</i>	ppm	0,10	0,056	0,0583	1

TEMPERATURE

°C	°F	°C	°F	°C	°F	°C	°F
-35	-31	40	104	115	239	190	374
-30	-22	45	113	120	248	195	383
-25	-13	50	122	125	257	200	392
-20	-4	55	131	130	266	205	401
-15	5	60	140	135	275	210	410
-10	14	65	149	140	284	215	419
-5	23	70	158	145	293	220	428
0	32	75	167	150	302	225	437
5	41	80	176	155	311	230	446
10	50	85	185	160	320	235	455
15	59	90	194	165	329	240	464
20	68	95	203	170	338	245	473
25	77	100	212	175	347	250	482
30	86	105	221	180	356	255	491
35	95	110	230	185	365	260	500

Conversion equations

$$T(^{\circ}\text{F}) = (1,8 \times T(^{\circ}\text{C})) + 32$$

$$T(^{\circ}\text{C}) = 0,55 \times (T(^{\circ}\text{F}) - 32)$$

$$T(\text{K}) = T(^{\circ}\text{C}) + 273,15$$

**MASS PER UNIT VOLUME OF DRY AIR (IN kg/m³)
FOR TEMPERATURES FROM 0 °C TO 300 °C AND PRESSURES FROM 0 TO 25 bar**

T (°C)	GAUGE PRESSURE (bar)										
	0	0,5	1	1,5	2	2,5	3	3,5	4	4,5	5
0	1,293	1,931	2,569	3,207	3,845	4,483	5,121	5,759	6,397	7,036	7,674
10	1,247	1,863	2,478	3,094	3,709	4,325	4,941	5,556	6,172	6,787	7,403
20	1,205	1,799	2,394	2,988	3,583	4,177	4,772	5,367	5,961	6,556	7,150
30	1,165	1,740	2,315	2,890	3,465	4,040	4,615	5,189	5,764	6,339	6,914
40	1,128	1,684	2,241	2,798	3,354	3,911	4,467	5,024	5,580	6,137	6,693
50	1,093	1,632	2,172	2,711	3,250	3,790	4,329	4,868	5,408	5,947	6,486
60	1,060	1,583	2,106	2,630	3,153	3,676	4,199	4,722	5,245	5,768	6,292
70	1,029	1,537	2,045	2,553	3,061	3,569	4,077	4,585	5,092	5,600	6,108
80	1,000	1,494	1,987	2,481	2,974	3,468	3,961	4,455	4,948	5,442	5,935
90	0,973	1,453	1,932	2,412	2,892	3,372	3,852	4,332	4,812	5,292	5,772
100	0,947	1,414	1,881	2,348	2,815	3,282	3,749	4,216	4,683	5,150	5,617
110	0,922	1,377	1,832	2,286	2,741	3,196	3,651	4,106	4,561	5,016	5,471
120	0,898	1,342	1,785	2,228	2,672	3,115	3,558	4,002	4,445	4,888	5,331
130	0,876	1,308	1,741	2,173	2,605	3,038	3,470	3,902	4,335	4,767	5,199
140	0,855	1,277	1,699	2,120	2,542	2,964	3,386	3,808	4,230	4,651	5,073
150	0,835	1,247	1,658	2,070	2,482	2,894	3,306	3,718	4,130	4,542	4,953
160	0,815	1,218	1,620	2,023	2,425	2,827	3,230	3,632	4,034	4,437	4,839
170	0,797	1,190	1,584	1,977	2,370	2,763	3,157	3,550	3,943	4,337	4,730
180	0,779	1,164	1,549	1,933	2,318	2,702	3,087	3,472	3,856	4,241	4,626
190	0,763	1,139	1,515	1,891	2,268	2,644	3,020	3,397	3,773	4,149	4,526
200	0,746	1,115	1,483	1,852	2,220	2,588	2,957	3,325	3,693	4,062	4,430
220	0,716	1,070	1,423	1,776	2,130	2,483	2,837	3,190	3,543	3,897	4,250
240	0,688	1,028	1,368	1,707	2,047	2,386	2,726	3,066	3,405	3,745	4,085
260	0,662	0,989	1,316	1,643	1,970	2,297	2,624	2,951	3,278	3,605	3,931
280	0,639	0,954	1,269	1,584	1,899	2,214	2,529	2,844	3,159	3,474	3,789
300	0,616	0,920	1,224	1,528	1,833	2,137	2,441	2,745	3,049	3,353	3,657

T (°C)	GAUGE PRESSURE (bar)										
	6	7	8	9	10	12	14	16	18	20	25
0	8,950	10,226	11,502	12,778	14,054	16,606	19,159	21,711	24,263	26,815	33,196
10	8,634	9,865	11,096	12,327	13,558	16,020	18,482	20,944	23,406	25,868	32,024
20	8,339	9,528	10,717	11,906	13,095	15,473	17,852	20,230	22,608	24,986	30,931
30	8,064	9,214	10,364	11,514	12,663	14,963	17,263	19,562	21,862	24,162	29,911
40	7,807	8,920	10,033	11,146	12,259	14,485	16,711	18,938	21,164	23,390	28,956
50	7,565	8,644	9,722	10,801	11,880	14,037	16,194	18,352	20,509	22,666	28,060
60	7,338	8,384	9,430	10,470	11,523	13,616	15,708	17,800	19,893	21,986	27,217
70	7,124	8,140	9,156	10,171	11,187	13,219	15,250	17,280	19,314	21,345	26,424
80	6,922	7,909	8,896	9,883	10,870	12,845	14,819	16,793	18,767	20,741	25,676
90	6,732	7,692	8,651	9,611	10,571	12,491	14,411	16,330	18,250	20,170	24,969
100	6,551	7,485	8,420	9,354	10,288	12,156	14,024	15,893	17,761	19,629	24,300
110	6,380	7,290	8,200	9,110	10,019	11,839	13,658	15,478	17,297	19,117	23,666
120	6,218	7,105	7,991	8,878	9,764	11,538	13,311	15,084	16,857	18,631	23,064
130	6,064	6,928	7,793	8,658	9,522	11,252	12,981	14,710	16,439	18,168	22,492
140	5,917	6,761	7,604	8,448	9,292	10,979	12,667	14,354	16,041	17,729	21,947
150	5,777	6,601	7,425	8,248	9,072	10,720	12,367	14,015	15,662	17,310	21,429
160	5,644	6,449	7,253	8,058	8,863	10,472	12,082	13,691	15,301	16,910	20,934
170	5,516	6,303	7,090	7,876	8,663	10,236	11,809	13,382	14,955	16,529	20,461
180	5,395	6,164	6,933	7,702	8,472	10,010	11,548	13,087	14,625	16,164	20,010
190	5,278	6,031	6,783	7,536	8,289	9,794	11,299	12,804	14,310	15,815	19,578
200	5,167	5,903	6,640	7,377	8,114	9,587	11,060	12,534	14,007	15,481	19,164
220	4,957	5,664	6,371	7,078	7,784	9,198	10,612	12,025	13,439	14,853	18,387
240	4,764	5,443	6,123	6,802	7,481	8,840	10,198	11,557	12,915	14,274	17,670
260	4,585	5,243	5,893	6,547	7,200	8,508	9,816	11,123	12,431	13,738	17,007
280	4,419	5,050	5,680	6,310	6,940	8,200	9,461	10,721	11,981	13,242	16,392
300	4,265	4,873	5,482	6,090	6,698	7,914	9,131	10,347	11,563	12,780	15,820

PHYSICAL PROPERTIES OF GASES AND VAPOURS – SI UNITS

Referred to 0°C (32F) and 1013,25 mbar (14,7 psia)

ρ - mass per unit volume

V - specific volume

T_f - melting temperature

C_p - specific heat at constant pressure

T_e - boiling temperature

λ - thermal conductivity

ρ_e - mass per unit volume of the liquid at T_e

Gas or Vapour	Formula	ρ (kg/m ³)	T_f (°C)	T_e (°C)	ρ_e (kg/m ³)	V (m ³ /kg)	C_p (kcal/kg.h.°C)	λ (kcal/m.h.°C)
Acetone	C ₃ H ₆ O	2,591	-94,8	56,2	749	0,386	0,296	0,0083
Acetylene	C ₂ H ₂	1,162	-83,3	-83,6	613	0,861	0,386	0,0158
Ammonia	NH ₃	0,76	-77,9	-33,4	680	1,316	0,491	0,0187
Argon	Ar	1,782	189,2	-185,7	1820	0,561	0,125	0,014
Benzole	C ₆ H ₆	3,485	-	-	-	0,287	0,227	0,0076
Biogas (40% CH ₄)	-	1,467	-	-	-	-	-	-
Biogas (56% CH ₄)	-	1,267	-	-	-	-	-	-
Biogas (70% CH ₄)	-	1,092	-	-	-	-	-	-
Butane	C ₄ H ₁₀	2,593	-138,4	-0,5	602	0,386	0,382	0,0119
Carbon dioxide	CO ₂	1,964	-56,6	-78,2	1219	0,509	0,195	0,0122
Carbon disulphide	CS ₂	3,397	-	-	-	0,294	0,139	0,0058
Carbon monoxide	CO	1,25	-205	-191,6	801	0,8	0,248	0,0191
Chlorine	Cl ₂	3,164	-101	-34,6	1512	0,316	0,116	0,0073
Diethyl ether	C ₄ H ₁₀ O	3,307	-	-	-	0,302	0,345	0,0108
Dry air	-	1,293	-213	-192,3	875	0,773	0,24	0,0209
Ethane	C ₂ H ₆	1,342	-183,3	-88,6	546	0,745	0,394	0,0155
Ethyl alcohol	C ₂ H ₆ O	2,055	-114,2	78,3	747	0,487	0,364	0,0119
Ethylene	C ₂ H ₄	1,251	-169,5	-103,7	568	0,799	0,349	0,0144
Helium	He	0,179	-272,2	-268,9	125	5,599	1,25	0,1233
Hydrochloric acid	HCl	1,627	-111,2	-84,8	1135	0,615	0,19	0,0072
Hydrogen	H ₂	0,09	-259,1	-252,9	71	11,118	3,45	0,1508
Hydrogen sulphide	H ₂ S	1,52	-85,6	-60,4	957	0,658	0,237	0,0108
Methane	CH ₄	0,716	-182,5	-161,5	415	1,397	0,517	0,0263
Methyl alcohol	CH ₄ O	1,429	-97,6	64,7	737	0,7	0,32	0,012
Natural gas	-	0,6	-	-	-	-	-	-
Nitrogen	N ₂	1,25	-209,9	-195,8	810	0,8	0,247	0,0205
Oxygen	O ₂	1,428	-218,4	-183	1131	0,7	0,218	0,0208
Propane	C ₃ H ₈	1,968	-187,7	-42,1	585	0,508	0,37	0,013
Propylene	C ₃ H ₆	1,877	-185	-47,8	686	0,533	0,34	-
Sulfur dioxide	SO ₂	2,858	-	-	-	0,35	0,14	0,0072

PHYSICAL PROPERTIES OF WATER – SI UNITS

t_{ref} – reference temperature for					Ca – actual specific heat at t_{ref}				
M_s – mass per unit volume at 20°C (68°F)					λ – thermal conductivity at t_{ref}				
Temp. (°C)	M_s (kg/m ³)	V (m ³ /kgx1000)	Ca (kcal/kg.°C)	λ (kcal/m.h.°C)	Temp. (°C)	M_s (kg/m ³)	V (m ³ /kgx1000)	Ca (kcal/kg.°C)	λ (kcal/m.h.°C)
0	999,87	1,00013	–	–	70	977,81	1,02269	1,0002	0,57
4	999,99	1,00001	–	–	71	977,23	1,0233	–	–
6	999,97	1,00003	–	–	72	976,66	1,0239	–	–
8	999,89	1,00011	–	–	73	976,07	1,02452	–	–
10	999,75	1,00025	1	0,493	74	975,48	1,02514	–	–
12	999,55	1,00045	–	–	75	974,89	1,02576	1,0013	0,574
14	999,3	1,0007	–	–	76	974,29	1,02639	–	–
16	999	1,001	–	–	77	973,68	1,02703	–	–
18	998,65	1,00135	–	–	78	973,07	1,02768	–	–
20	998,2	1,0018	1	0,51	79	972,45	1,02833	–	–
22	997,83	1,00217	–	–	80	971,83	1,02899	1,0025	0,577
24	997,37	1,00264	–	–	81	971,21	1,02964	–	–
26	996,87	1,00314	–	–	82	970,57	1,03032	–	–
28	996,33	1,00368	–	–	83	969,94	1,03099	–	–
30	995,76	1,00426	1	0,526	84	969,3	1,03167	–	–
32	995,12	1,0049	–	–	85	968,65	1,03236	1,0037	0,58
34	994,49	1,00554	–	–	86	968	1,03306	–	–
36	993,74	1,0063	–	–	87	967,34	1,03376	–	–
38	993,02	1,00703	–	–	88	966,68	1,03447	–	–
40	992,24	1,00782	1	0,539	89	966,01	1,03519	–	–
41	991,86	1,00821	–	–	90	965,34	1,0359	1,0049	0,582
42	991,47	1,0086	–	–	91	964,67	1,03662	–	–
43	991,07	1,00901	–	–	92	963,99	1,03736	–	–
44	990,66	1,00943	–	–	93	963,3	1,0381	–	–
45	990,25	1,00985	–	–	94	962,61	1,03884	–	–
46	989,82	1,01028	–	–	95	961,92	1,03959	1,006	0,584
47	989,4	1,01071	–	–	96	961,22	1,04034	–	–
48	988,96	1,01116	–	–	97	960,51	1,04111	–	–
49	988,52	1,01161	–	–	98	959,81	1,04187	–	–
50	988,07	1,01207	1	0,551	99	959,09	1,04266	–	–
51	987,62	1,01254	–	–	100	958,38	1,04343	1,0061	0,586
52	987,15	1,01302	–	–	105	–	–	1,0071	0,588
53	986,69	1,01349	–	–	110	–	–	1,0084	0,589
54	986,21	1,01398	–	–	115	–	–	1,0098	0,59
55	985,73	1,01448	1	0,556	120	–	–	1,0114	0,591
56	985,25	1,01497	–	–	125	–	–	1,0132	0,591
57	984,75	1,01549	–	–	130	–	–	1,0152	0,592
58	984,25	1,016	–	–	135	–	–	1,0175	0,592
59	983,75	1,01652	–	–	140	–	–	1,02	0,592
60	983,24	1,01705	1	0,561	145	–	–	1,0228	0,591
61	982,72	1,01758	–	–	150	–	–	1,0258	0,591
62	982,2	1,01812	–	–	160	–	–	1,0328	0,589
63	981,67	1,01867	–	–	170	–	–	1,0411	0,586
64	981,13	1,01923	–	–	180	–	–	1,0507	0,582
65	980,59	1,01979	1	0,566	190	–	–	1,0619	0,578
66	980,05	1,02036	–	–	200	–	–	1,0746	0,572
67	979,5	1,02093	–	–	210	–	–	1,089	0,565
68	978,94	1,02151	–	–	220	–	–	1,1052	0,558
69	978,38	1,0221	–	–	230	–	–	1,1234	0,55

PHYSICAL PROPERTIES OF LIQUIDS – SI UNITS

T _{ref} – reference temperature for M _s – mass per unit volume at 20°C (68°F)					Ca – actual specific heat at t _{ref} λ – thermal conductivity at t _{ref}				
Liquid	T _{ref} (°C)	M _s (kg/m ³)	Ca (kcal/kg.°C)	λ (kcal/m.h.°C)	Liquid	T _{ref} (°C)	M _s (kg/m ³)	Ca (kcal/kg.°C)	λ (kcal/m.h.°C)
Acetic acid	25	1049	0,51	0,166	Methane	- 90	162	-	-
Acetone	20	790	0,515	0,139	Methanol	20	791	0,33	-
Ammonia sol. (25%)	20	771	-	0,425	Methyl alcohol (95%vol.)	20	792	0,596	0,174
Apple juice	20	1356	0,446	-	Milk, cow, heavy cream	20	994	0,94	0,434
Argon	-186	1430	-	-	Naphta	15	665	0,92	-
Automobile oils	15	880-940	-	0,125	Nitric acid	20	1520	0,411	0,456
Beer	10	1010	-	-	Nitrogen	-201	808	-	-
Benzene	20	870	0,43	0,138	Oil, coconut	20	924	-	-
Benzole	20	879	0,43	0,132	Oil, corn	20	922	-	-
	80	-	0,44	0,13	Oil, castor	25	956,1	0,43	0,155
Butane	25	599	0,55	-	Oil, cotton seed	15	926	-	-
Butter	20	911	0,557-0,688	-	Oil, olive	10	918	0,47	0,146
Carbon tetrachloride	25	1584	0,207	0,089	Oil, palm	20	915	-	-
Carbon disulphide	20	1266	0,241	0,138	Oil, soya	20	927	0,47	-
Chloride	25	1560	-	-	Oil, sunflower	20	920	-	-
Chloroform	20	1489	0,251	0,11	Oil, peanut	20	914	-	-
Citric acid	25	1660	-	-	Oil, whale	15	925	-	-
Crude oil	20	900	-	0,113	Oxygen (liquid)	-186	1155	-	-
Diesel	20	800	-	-	Petrol	30	680 - 710	0,45	0,112
Ethane (liquid)	-89	570	-	-	Phenol	25	1072	0,34	0,163
Ethyl acetate	20	901	-	-	Propanol	25	804	-	-
Ethyl alcohol (95%vol.)	0	789	0,547	0,166	Propyl alcohol	25	800	0,57	0,138
	40	-	0,648	0,144	Sea water	25	1025	0,94	-
Fuel oil	20	840 - 920	0,471	0,103	Sodium carbonate	20	2530	0,86	0,516
Gasoline	20	803	0,53	0,129	Sodium Hydroxide (caustic soda)	15	1250	0,77	0,37
Glycerine	10	1260	0,576	0,25	Sulphuric acid	12	1853	0,33	0,28
Glycerol	25	1126	-	-	Sulphurous acid (96%)	20	1840	0,351	0,43
Helium	-271	147	-	-	Water	8	999,88	1	0,485
Honey	20	1420	0,54-0,6	0,00648		41	991,66	1	0,538
Hydrazine	25	795	-	-		72	976,36	1	0,58
Hydrochloric acid (25%)	20	1150	0,75	0,404		100	958,38	1,006	0,586
Kerosene	16	820,1	0,48	0,125		200	0 - 200	1,037	0,572
Lubricating oil	81	920	-	0,105					
	0	-	-	0,133					
	100	-	-	0,128					
	200	-	-	0,122					

PHYSICAL PROPERTIES OF METALS – SI UNITS

Metal	T _{ref} (°C)	Ms (kg/m ³)	λ - thermal conductivity at t _{ref}	Ca - actual specific heat at t _{ref}
			λ (kcal/m.h.°C)	Ca (kcal/kg.h.°C)
Alloy Steel (5%Cr)	20	7790	28	0,11
	20	7670	20	0,11
	20	7760	27	0,11
Alloy Steel (5%Ni)	30	7850	25	-
	30	-	22	-
	30	8120	9	-
	30	-	14	-
Aluminum	0	2700	173	0,21
	100	-	176	0,224
	300	-	198	0,241
Brass	20	8400	79-96	-
	100	-	90-110	-
Bronze	20	8700	50	0,0913
	100	-	62	0,0937
Carbon Steel (0,1%C)	100	7830	47	-
	300	-	43	-
	600	-	32	-
Carbon Steel (0,5%C)	100	7820	45	0,113
	300	-	38	-
	600	-	31	-
Carbon Steel (1,5%C)	100	7740	32	-
	300	-	31	-
	600	-	29	-
Cast Iron (4%C)	20	-	50	-
Chromium	0	7190	-	0,102
	100	-	-	0,113
	300	-	-	0,125
Copper	20	8960	332	0,0911
Gold	0	19320	268	0,0311
	200	-	266	-
Magnesium	100	1738	135	0,257
Nikel	10	8902	54	0,105
	500	-	44	-
Silver	0	10500	360	0,057
	100	-	312	0,0572
	900	-	-	0,0676
Tin	0	7310	56	0,0536
	200	-	52	-
Zinc	0	7133	95	0,0918
	200	-	90	-

FLASH STEAM FROM BOILING CONDENSATE

