

FLOAT AND THERMOSTATIC STEAM TRAPS FLT314TW

DESCRIPTION

The FLT314TW is a series of high capacity float and thermostatic steam traps with integral air vent, designed for modulating discharge of condensate to ensure maximum system heat transfer. Specially designed for applications where continuous drainage is essential and high loads are involved.

MAIN FEATURES

High capacity.
Modulating discharge of condensate at steam temperature.
Unaffected by sudden or wide load and pressure variations.
No backing-up with condensate.
Excellent air discharge through its integrated thermostatic air vent.

OPTIONS: Equalizing (vent) and drain connections.
HVV – Hand vent valve.
BDV – Blowdown valve.
AFZ – Anti-freeze device.
VB21M – Vacuum breaker.

USE: Saturated and superheated steam.

AVAILABLE MODELS: FLT314STW – carbon steel.

SIZES: 3" – DN 80.

CONNECTIONS: Flanged EN 1092-1 PN 16.
Flanged ASME B16.5 Class 150.

INSTALLATION: Horizontal installation.
See IMI – Installation and maintenance instructions.



BODY LIMITING CONDITIONS *	
FLANGED PN 16 / CLASS 150 ALLOWABLE PRESSURE	RELATED TEMPERATURE
14,8 bar	100 °C
13,3 bar	200 °C
12,1 bar	250 °C
11 bar	300 °C

PMO – Max. operating pressure: 12 bar.
TMO – Max. operating temperature: 250 °C.
* According to EN 1092-1:2018.

CE MARKING – GROUP 2 (PED – European Directive)	
PN 16	Category
3" – DN 80	2 (CE marked)

FLOW RATE CAPACITY (kg/h)																	
MODEL	SIZE	DIFFERENTIAL PRESSURE (bar)															
		0,1	0,3	0,5	1	1,5	2	2,5	3	3,5	4	5	6	7	8	10	12
FLT314STW	3" – DN 80	37600	45400	49000	58000	62000	68000	74000	76000	79000	84000	87000	91000	94000	96000	99000	100000

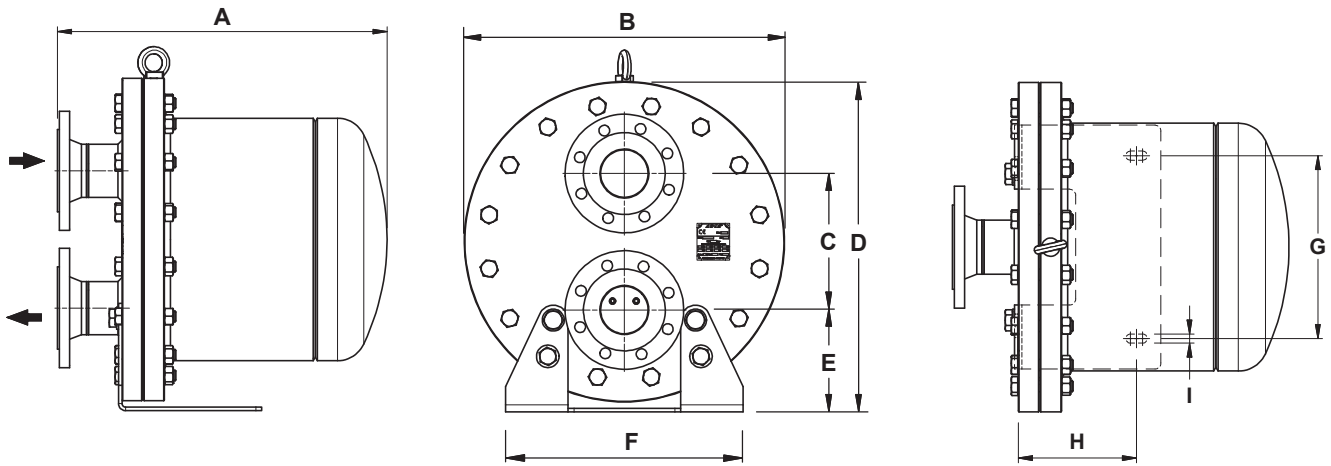

DIMENSIONS (mm)												
MODEL	SIZE	A PN 16	A CL. 150	B	C	D	E	F	G	H	I	WEIGHT (kg)
FLT314STW	3" - DN 80	552	572	540	230	557	172	400	300	194	15	160

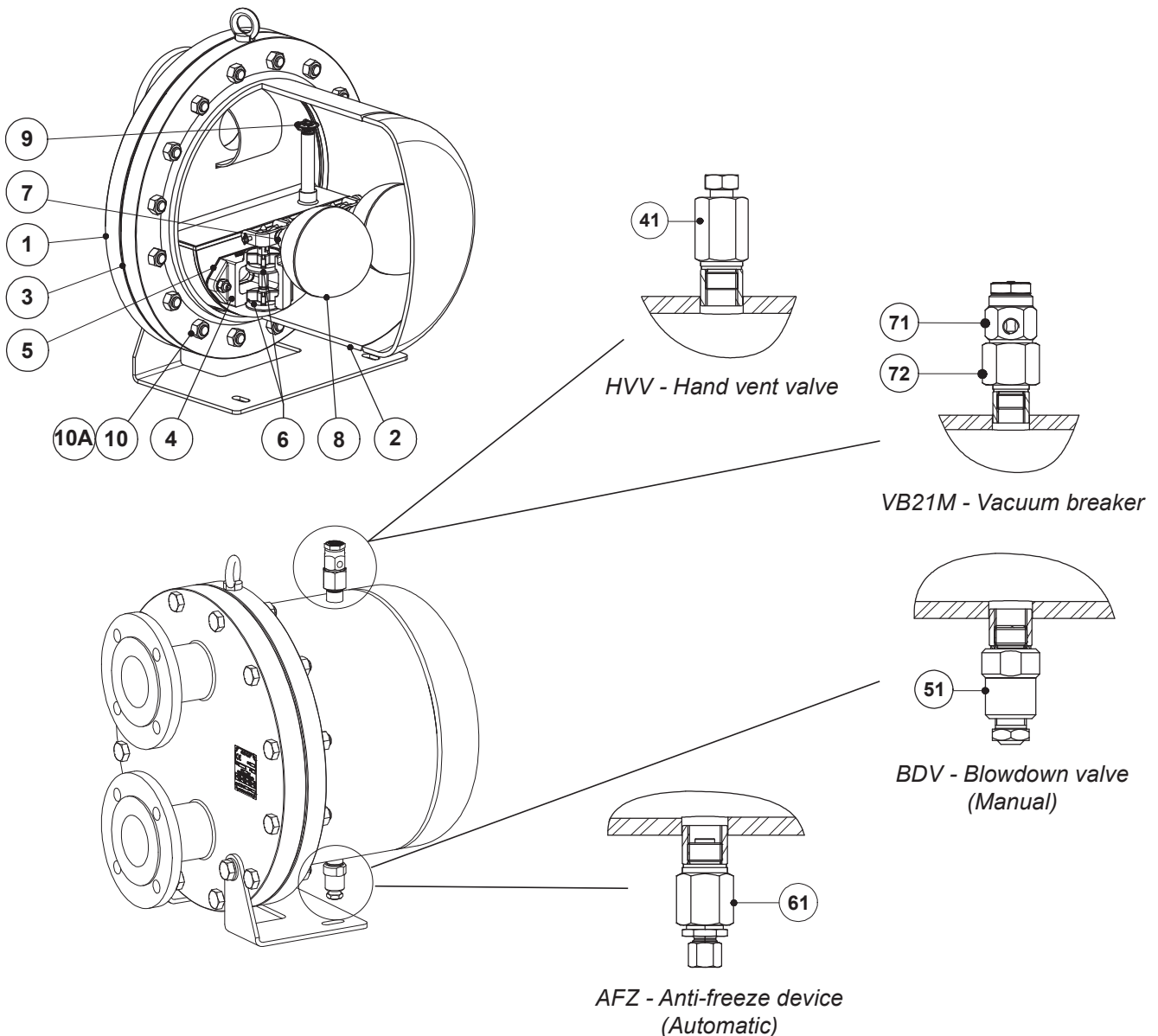

MATERIALS		
POS. N°	DESIGNATION	MATERIAL
1	Body	P250GH / 1.0460; P235GH / 1.0345; S355JR / 1.0045; S235JR / 1.0038
2	Cover	P265GH / 1.0425; P250GH / 1.0460; P235GH / 1.0345; S355JR / 1.0045
3	* Gasket	Stainless steel / Graphite
4	* Seat	A351 CF8M / 1.4408
5	* Gasket	Stainless steel / Graphite
6	* Valve	AISI 420 / 1.4021; A351 CF8M / 1.4408
7	* Lever	AISI 316 / 1.4401; AISI 304 / 1.4301
8	* Float	AISI 304 / 1.4301
9	* Automatic air vent	Stainless steel (thermostatic)
10	Bolts	Steel 8.8
10A	Nuts	Steel 8.8
11	Plug	AISI 316L / 1.4404
12	** Gasket	Copper
41	Hand vent valve	AISI 303 / 1.4305; AISI 316L / 1.4404
51	Blowdown valve	AISI 303 / 1.4305; AISI 316L / 1.4404
61	Anti-freeze device	AISI 303 / 1.4305; AISI 316L / 1.4404
71	Vacuum breaker	AISI 303 / 1.4305
72	Adapter fitting	AISI 303 / 1.4305

* Available spare parts.