

## THERMODYNAMIC STEAM TRAP UDT46 (For use with universal pipeline connectors)

### DESCRIPTION

The UDT46 series thermodynamic steam traps, completely in stainless steel, are excellent for high pressure systems, including steam tracing applications. The insulation cover ensures a consistent operation and makes them particularly suitable for applications where the weather conditions, such as rain and wind, may affect the normal operation. These traps have only one moving part and offer a wide operating range, without adjustment. These traps fit the UCX universal connectors and CTS4U compact stations.



### MAIN FEATURES

- Intermittent discharge.
- Standard insulation cover.
- Operates on superheated steam.
- Replaceable seat and disc.
- Unaffected by water hammer and vibrations.

USE: Saturated and superheated steam.  
 AVAILABLE MODELS: UDT46.

SIZES: According to the selected pipeline connector.

INSTALLATION: See IMI – Installation and maintenance instructions.

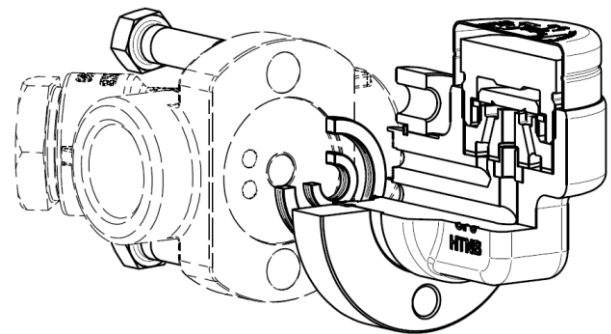

BODY LIMITING CONDITIONS	
FLANGED ANSI 300 lb ALLOW. PRESS.	RELATED TEMP.
47,8 bar	-10 / 50 °C
40,9 bar	100 °C
34,4 bar	200 °C
30,6 bar	300 °C
28,6 bar	400 °C

PMO – Max. operating pressure 32 bar;  
 TMO – Max. operating temperature 245 °C;  
 Min. Working pressure 1,5 bar;  
 Max. working backpressure 80%.  
 The connector may restrict the operating conditions to a lower rating.

FLOW RATE CAPACITY (kg/h)												
MODEL	DIFFERENTIAL PRESSURE (bar)											
	1,5	3	5	7	9	12	15	18	21	24	30	32
UDT46 (Hot)	70	100	130	175	190	200	225	240	250	270	290	300
UDT46 (Cold)	170	230	300	335	390	435	485	520	575	600	645	695

DIMENSIONS (mm)						
MODEL	A	B	ØC	ØD	E	WGT. (kg)
UDT46	78	35	67	50	49	1,1

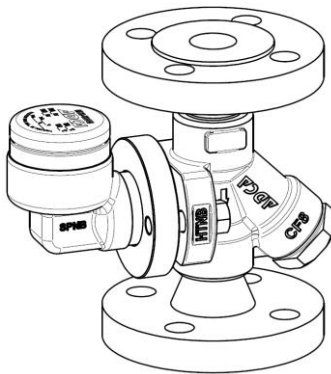
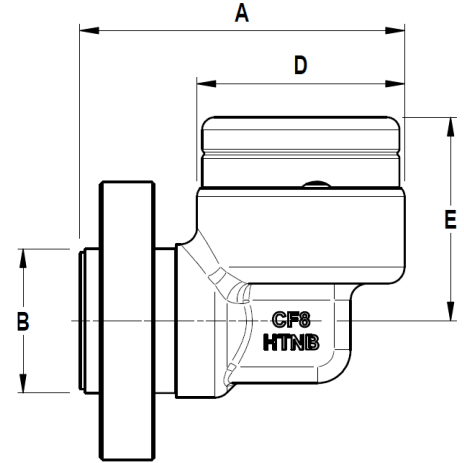
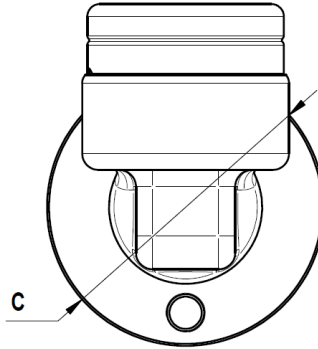
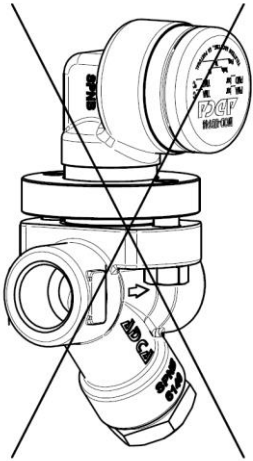

UDT steam trap connected to a UCX universal pipeline connector

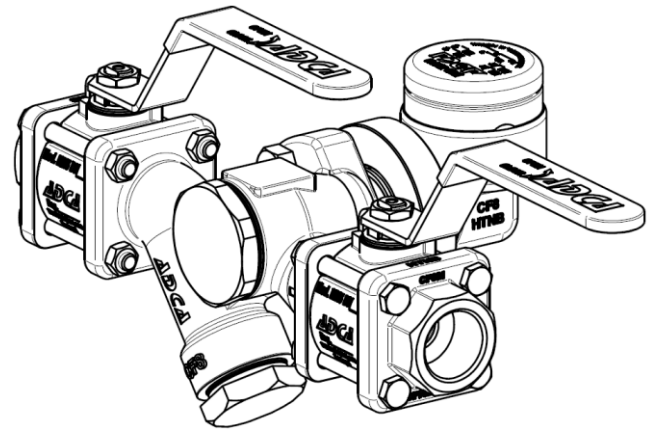

UDT steam trap connected to a CTS4U compact station

MATERIALS		
POS. N°	DESIGNATION	MATERIAL
1	Body	CF8 / 1.4308
2	Cover	AISI 304 / 1.4301 AISI 303 / 1.4305
3	Valve seat	Hardened stainless steel
4	Valve disc	Hardened stainless steel
5	Washer support	AISI 304 / 1.4301
6	Bimetallic ring	Bimetal
7	* Gasket	Stainless steel / Graphite
8	* Tube	AISI 304 / 1.4301
9	* Inlet gasket	Stainless steel / Graphite
10	* Outlet gasket	Stainless steel / Graphite
11	Flange	AISI 316 / 1.4401
12	Retainer ring	Steel
13	Bolts	ASTM A193 Gr. B7
14	Insulation cover	AISI 304 / 1.4301

\* Available spare parts.

