

THERMOSTATIC STEAM TRAPS AND AIR VENTS TH32i

DESCRIPTION

The TH32i series thermostatic steam traps and air vents are specifically designed for use on process equipment such as kettle cookers, sterilizers, food, chemical and laundry equipment.

MAIN FEATURES

- Modulating discharge.
- Discharges condensate close to steam temperature.
- Thermostats for different sub cooling (5 °C to 30 °C).
- Excellent air discharge.
- Operates on moderate superheated steam.
- Built-in strainer.

OPTIONS: LC – low capacity.
Integral check valve.
Blowdown valve.

USE: Saturated steam.

AVAILABLE MODELS: TH32i – stainless steel.
TH32i-CK – stainless steel, with check valve.

SIZES: 1/2" to 1"; DN 15 to DN 25.

CONNECTIONS: Female threaded ISO 7 Rp or NPT.
Flanged EN 1092-1 PN 40.
Flanged ASME B16.5 Class 150 or 300.
Socket weld (SW) ASME 16.11.
Butt weld (BW) ASME B16.25 on request.

INSTALLATION: Horizontal installation recommended, can be installed in any position.
See IMI – Installation and maintenance instructions.



CE MARKING – GROUP 2 (PED – European Directive)

PN 40	Category
1/2" to 1" – DN 15 to 25	SEP

BODY LIMITING CONDITIONS			
FLANGED PN 40 *	FLANGED CLASS 150 **	FLANGED CLASS 300 **	RELAT. TEMP.
ALLOW. PRESSURE	ALLOW. PRESSURE	ALLOW. PRESSURE	
40 bar	15,3 bar	39,9 bar	50 °C
34,4 bar	12 bar	31,3 bar	150 °C
29,9 bar	10,2 bar	26,6 bar	250 °C
27,6 bar	9,7 bar	25,2 bar	300 °C

PMO – Max. operating pressure: 22 bar.
TMO – Max. operating temperature: 250 °C.
* Acc. to EN 1092-1:2018. ** Acc. to EN 1759-1:2004.
Body limiting conditions PN 40 or below, depending on the type of connection adopted. Rating PN 40 for threaded, SW and BW versions.

FLOW RATE CAPACITY (kg/h)																
MODEL	SIZE	DIFFERENTIAL PRESSURE (bar)														
		0,2	0,3	0,5	1	1,5	2	3	4	6	8	10	13	15	20	22
TH32i	1/2" to 1" DN 15 to 25	70	120	140	255	330	385	455	510	600	670	700	720	750	775	795
TH32iLC	1/2" to 1" DN 15 to 25	45	55	70	95	125	135	180	200	270	315	330	360	370	405	415

Capacities shown refer to condensate at 10 °C below saturated steam temperature (standard type S thermostat).
Thermostats for 5 °C (type H) and 30 °C (type L) also available. Capacities for cold condensate discharge at 20 °C are two to three times greater.

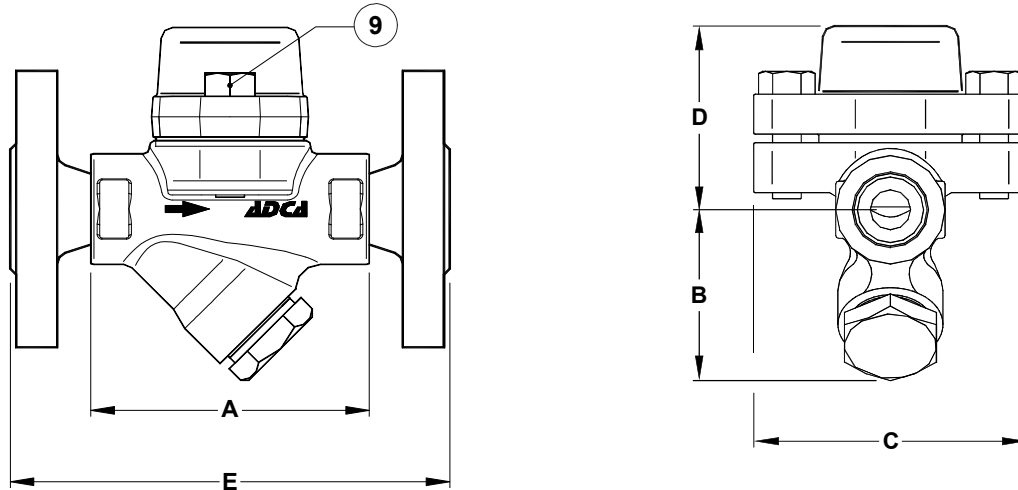

DIMENSIONS (mm)											
SIZE	THREADED / SW					PN 40		CLASS 150		CLASS 300	
	A	B	C	D	WEIGHT (kg)	E	WEIGHT (kg)	E	WEIGHT (kg)	E	WEIGHT (kg)
1/2" – DN 15	95	59	95	65	1,6	150	3,2	150	2,7	150	3,5
3/4" – DN 20	95	59	95	65	1,6	150	3,9	150	3,1	150	4,7
1" – DN 25	95	65	95	65	1,8	160	4,7	160	4,3	160	5,9

MATERIALS		
POS. N°	DESIGNATION	MATERIAL
1	Body	AISI 316L / 1.4404
2	Cover	AISI 316L / 1.4404
3	* Gasket	Stainless steel / Graphite
4	* Valve seat	AISI 304 / 1.4301
5	* Thermostatic element	Stainless steel
6	* Strainer screen	AISI 304 / 1.4301
7	* Gasket	Stainless steel / Graphite
8	* Strainer cover	AISI 303 / 1.4305
9	Bolts	Stainless steel A2-70

* Available spare parts.

