

**BLOWDOWN CONTROLLER
BCS220**

DESCRIPTION

The ADCATrol BCS220 is a blowdown controller specially designed for use with steam boilers. The device takes care of both TDS and intermittent blowdown controls.

TDS (Total Dissolved Solids) is controlled through measurement of the boiler water electrical conductivity and intermittent control is performed via a blowdown timer.

The device utilizes a clear multifunction LCD to display measured conductivity, temperature, operational alarm status and provide an intuitive user interface. The device is IP 66 rated NEMA 4X and can be panel, surface/wall and pipe mounted.



MAIN FEATURES

- TDS and intermittent blowdown control in one single device.
- Displays conductivity, resistivity, PPM and temperature units.
- Programmable cell constant.
- Versatile IP 66 NEMA 4X (144 x 144 mm) enclosure design.
- Large informative 3,75" LCD backlit display.
- Simple intuitive menu structure with soft tactile function buttons.
- Software upgradable via SD card slot – Future proof.
- Volt-free outputs with multiple alarm function options.
- 0(4) to 20 mA analog output for remote monitoring purposes with features including adjustable scaling, selectable on-error states and loop fault detection.
- Digital input suitable for connection to the boiler stand-by/burner contact, to reduce energy waste.

OPTIONS AND

- ACCESSORIES:** Panel mounting kit.
Pipe mounting kit (50 to 100 mm pipe OD).

AVAILABLE

- MODELS:** BCS220 – 90 to 265 V AC power supply.
BCS220-LV – 12 to 30 V DC power supply.

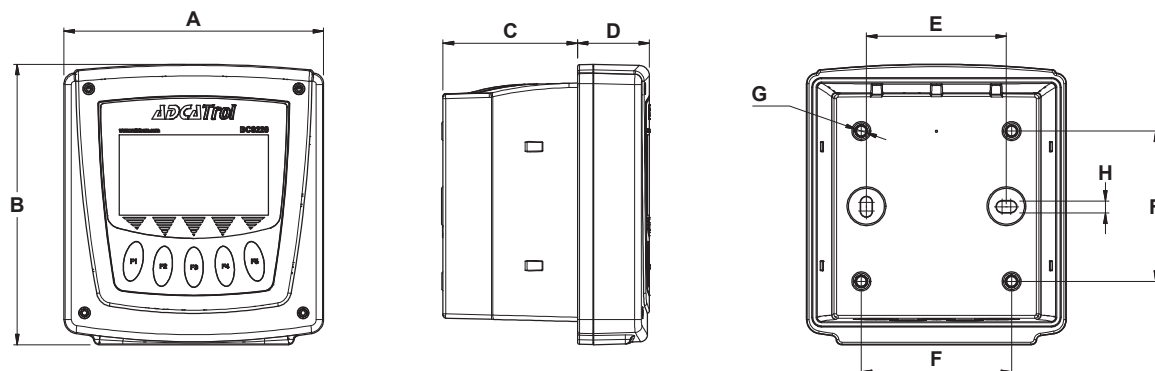

DIMENSIONS (mm)									
MODEL	A	B	C	D	E	F	G	H	WEIGHT (kg)
BCS220 BCS220-LV	150	161	77	42	80	86	M4	6,8	0,8

TECHNICAL DATA

GENERAL	
Supply voltage	90 to 265 V AC, 10 W max. (standard model) 12 to 30 V DC, 5 W max. (LV model)
IP rating	IP 66 NEMA 4X
Material	Housing in PC/ABS
Ambient temperature	-20 to +55 °C
Ambient humidity	5 to 95 %, non condensing
Front panel	144 x 144 mm (cutout: 138 x 138 mm)
Display	3,75" 240 x 128 dot LCD module *
Language	English, Portuguese, French, Spanish and Italian

* Backlight can be set to flash to indicate the instruments alarm status.

INPUTS AND OUTPUTS	
Digital inputs	1 NO/NC contact input
Relay outputs	2 NO volt free contacts 5A @ 30 V DC / 5A @ 250 V AC
Analog output *	0(4) to 20 mA, 750 ohms max., fully isolated to 2 kV
MicroSD card interface	SD, SDHC and SDXC-FAT32 cards supported

* Expandable across operating range. Includes loop fault detection.

CONDUCTIVITY, TDS AND RESISTIVITY	
Measuring ranges *	0 to 99,99 µS/cm up to 0 to 999,9 mS/cm (K= 0,01 to 10,0) 0 to 99,99 KΩ/cm up to 0 to 9,999 MΩ/cm (K= 0,01 to 1,0) 0 to 99,99 ppm up to 0 to 99,99 ppt
Cell constant adjustment	Fully adjustable from 0,005 to 15
Cell constant calibration	± 50% of nominal cell constant
Range selection	Internal single or auto range
Conductivity accuracy	± 0,5% of range
Linearity	± 0,1% of range
Repeatability	± 0,1% of range
Operator adjustment (conductivity)	± 10 % slope (gain) adjustment for solution calibration
Sensor input filter	Adjustable filter that averages the sensor input over a user selectable time (10 sec. to 5 min.)

* See conductivity, TDS and resistivity range tables for further information.

TEMPERATURE COMPENSATION	
Range of temperature measurement	50 °C to 300 °C
Temperature accuracy	± 0,5 °C
Temperature sensor	Pt100 or Pt1000 RTD (2,3 or 4 wire)
Temperature compensation type	Automatic or manual (- 0 to 9,99 %/°C)
Temperature compensation base	Selectable at 20 °C or 25 °C
Range of temperature compensation	-10 °C to +300°C

DIRECTIVES	
Electromagnetic compatibility directive	2014/30/EU using EN 61326-1:2013
Low voltage directive	2014/35/EU using EN 61010-1:2010
RoHS directive	2011/65/EU using EN 50581:2012

CONDUCTIVITY RANGE				
Conductivity range	Nominal cell constant			
	0,01	0,1	1	10
0 to 9,999 µS/cm	•	•		
0 to 99,99 µS/cm	•	•	•	
0 to 999,9 µS/cm		•	•	•
0 to 9999 µS/cm			•	•
0 to 99,99 mS/cm *			•	•
0 to 999,9 mS/cm *				•

* Maximum measurement range will be limited by the solution temperature. With the temperature compensation slope set to 2%/°C the range will derate linearly from full scale at 25°C to 50% of scale at 100°C.

TOTAL DISSOLVED SOLIDS RANGE				
TDS range	Nominal cell constant			
	0,010	0,1	1	10
0 to 9,999 ppm	•	•		
0 to 99,99 ppm	•	•	•	
0 to 999,9 ppm		•	•	•
0 to 9999 ppm			•	•
0 to 99,99 ppt				•

RESISTIVITY RANGE				
Resistivity range	Nominal cell constant			
	0,010	0,1	1	10
0 to 99,99 kΩ-cm		•	•	
0 to 999,9 kΩ-cm	•	•		
0 to 9,999 MΩ-cm	•	•		
0 to 99,99 MΩ-cm	•			