

ELECTRIC CONDENSATE RECOVERY UNITS ECRUV

DESCRIPTION

The ADCAMat ECRUV series of electric condensate recovery units are recommended in the transfer of high-temperature water such as hot condensate, to a higher elevation or pressure. This condensate is usually used as boiler feedwater. The standard models are prepared for flows up to 4 m³/h. The units are composed of a vertical condensate vessel (receiver), a metallic support frame, electric pump, level controls, valves, prewired control panel and pipework for connections between the different elements of the units.

OPERATION

The condensate is brought into the vessel through the inlet connections, with stainless steel sparge pipes, located on the top of the vessel. As the condensate level rises it will trigger the level control system to start the pumping process.

MAIN FEATURES

Condensate vessel – Completely manufactured from carbon steel or AISI 316 stainless steel, with inlet connections, overflow, air vents, drain, pump feeding outlets and a set of conductive level switches.

Metal frame – Manufactured from structural steel (sandblasted and painted) or stainless steel (sandblasted).

Pump – Manufactured from stainless steel, capable of handling hot condensate up to 98 °C and designed for low NPSH.

Control panel – Metal enclosure rated to IP 65 or higher. Features pump fault indication, level alarms, operating mode selector switch and volt-free telemetry terminals for remote stats. The unit requires a 3 phase, 380 to 415 V AC, 50 Hz power supply.

OPTIONS:

- Thermal insulated vessel.
- Full or partial stainless steel construction.
- Different pumping capacities.
- Alternative designs.

AVAILABLE

MODELS:

- ECV150 2T10 – 150L vessel capacity, 2 m³/h flow rate and 10 m delivery head.
- ECV225 4T10 – 225L vessel capacity, 4 m³/h flow rate and 10 m delivery head.
- Others on request.

CERTIFICATION: The ADCAMat ECRUV is designed to operate exclusively at atmospheric pressure and therefore is outside the scope of the European Pressure Equipment Directive. It complies with the European Machinery Directive and therefore carries the CE mark.

When supplied with an integrated control panel the compliance with the Low Voltage Directive and the Electromagnetic Compatibility Devices Directive is also ensured.

A declaration of conformity is delivered with the equipment according to the relevant Directives in use.



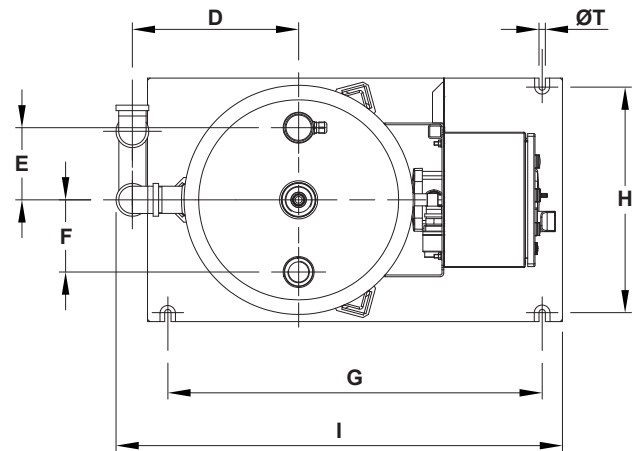
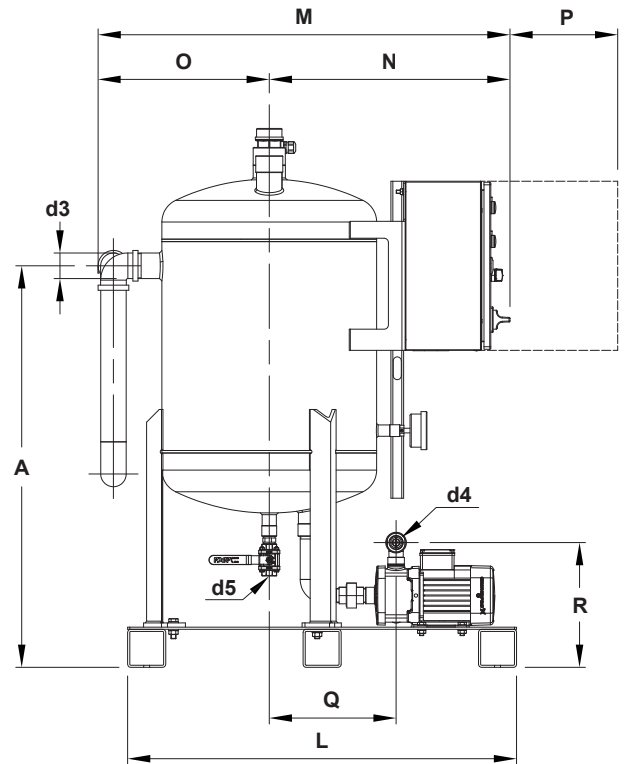
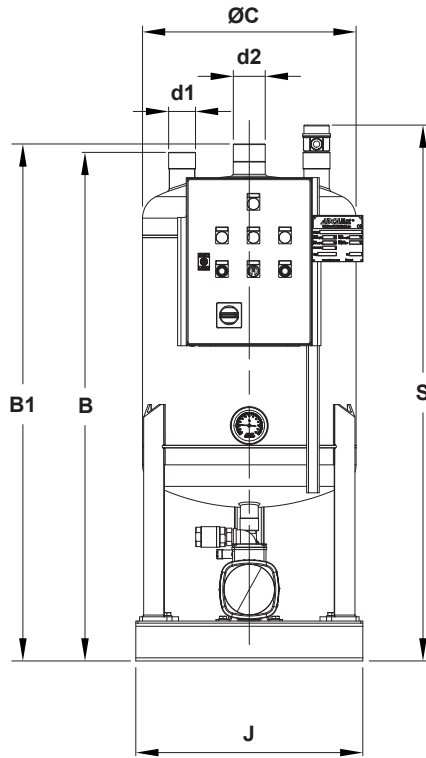

DIMENSIONS (mm) *																				
MODEL	A	B	B1	ØC	D	E	F	G	H	I	J	L	M	N	O	P	Q	R	S	ØT
ECV150 2T10	950	1210	1230	508	369	160	160	830	500	990	540	920	974	569	405	255	300	295	1275	14
ECV225 4T10	1400	1680	1680	508	369	160	150	890	500	1050	540	980	974	569	405	255	360	359	1725	14

* Dimensions and configuration may vary depending on the model.

CONNECTIONS					
MODEL	d1 *	d2 *	d3 **	d4 *	d5 *
ECV150 2T10	1 1/2"	2"	2"	1"	3/4"
ECV225 4T10	2"	2"	2"	1 1/2"	3/4"

d1 – condensate inlet; d2 – vent; d3 – overflow; d4 – condensate outlet; d5 – drain.

* As standard female threaded connections are ISO 7 Rp. Female threaded NPT connections are available on request.

** As standard male threaded connections are ISO 7 R. Male threaded NPT connections are available on request.

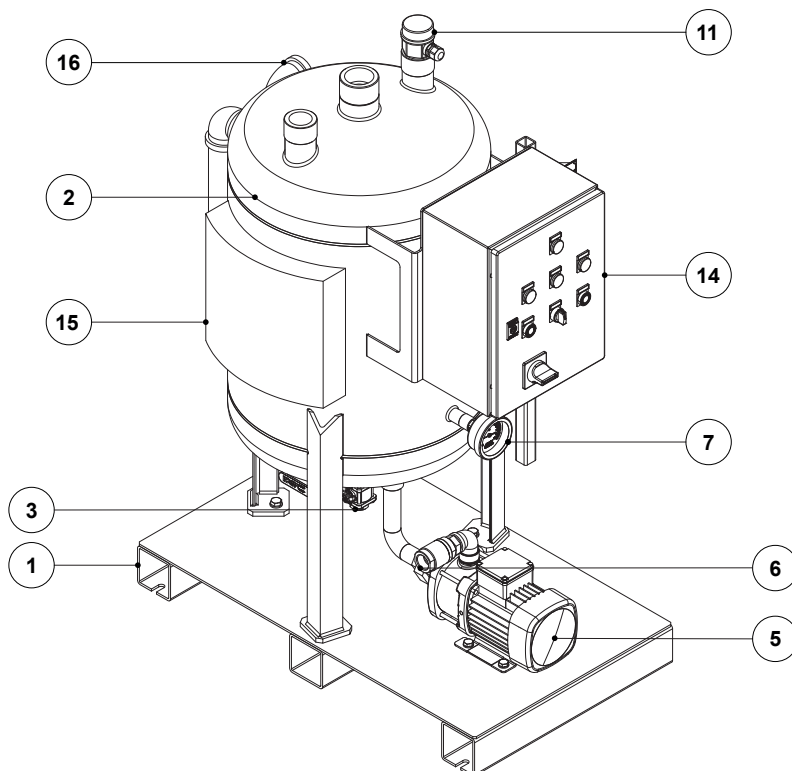

MATERIALS *			
POS. No.	DESIGNATION	CARBON STEEL / CAST IRON	STAINLESS STEEL
1	Metal frame	S235JR / 1.0038	AISI304 / 1.4301
2	Vessel	P235GH / 1.0325	AISI 316 / 1.4401
3	Ball valve	ADCA M3i5	ADCA M3i5
5	Electric pump	AISI 304 / 1.4301; AISI 316 /1.4401	AISI 304 / 1.4301; AISI 316 /1.4401
6	Check valve	ADCA RT25	ADCA RT25
7	Thermometer	ADCA TG90	ADCA TG90
11	Conductive switches (multipoint detection)	PP; Stainless steel	PP; Stainless steel
14	Control panel	Carbon steel	Stainless steel
15	Thermal insulation **	Rockwool / Aluminium	Rockwool / Aluminium
16	Overflow	P235GH / 1.0325	AISI 316 / 1.4401

* References shown are merely indicative and can be changed without notice.

** Optional.

ORDERING CODES ECRUV										
MODEL	ECV	150	S	S	2T10	S	S	X	X	
ECRUV – Electric condensate recovery unit (vertical design)		ECV								
VESSEL CAPACITY										
150 liters		150								
225 liters		225								
VESSEL MATERIAL										
Carbon steel			S							
AISI 316 / 1.4401 stainless steel			I							
NUMBER OF ELECTRIC PUMPS										
Single pump (3~ 380 – 415 V, 50 Hz)				S						
MAXIMUM FLOW RATE AND DELIVERY HEAD IN METERS AT THE MENTIONED FLOW										
2 m³/h at 10 metres (with 150 L vessel)					2T10					
4 m³/h at 10 metres (with 225 L vessel)					4T10					
METAL FRAME										
Fabricated carbon steel						S				
Fabricated stainless steel						I				
PIPEWORK										
Carbon steel							S			
Stainless steel							I			
CONTROL PANEL										
Without control panel								X		
Control panel with carbon steel enclosure, conductive switches and wiring								C		
Control panel with stainless steel enclosure, conductive switches and wiring								D		
THERMAL INSULATION										
Without thermal insulation									X	
Thermal insulation with aluminium external protection									T	
SPECIAL CONSTRUCTION / ADDITIONAL OPTIONS										
A full description must to be provided and validated in case of a non-standard construction										E

Remark: In case NPT connections are required, please specify with the order.