

## HYGIENIC BALL VALVES M3H (2 1/2" to 4" – DN 65 to DN 100)

### DESCRIPTION

The ADCAPure M3H three piece body ball valves are isolating valves designed for use with clean steam, condensate and other gases and liquids used in high purity and aseptic processes.

The valve is not designed as a control valve and should only be used as an isolating valve, fully open or fully closed.

The product is mainly designed for the pharmaceutical, biotech, semiconductor, cosmetics, fine chemical and food & beverage industries.

### MAIN FEATURES

True or full bore floating ball design.

Can be serviced without removal from the pipeline.

Tube weld with loose body flanges (360° rotation after installation).

Bidirectional.

Antistatic device.

Anti blow out proof stem.

ISO 5211 mounting.

### STANDARD SURFACE FINISH

Internal wetted parts:  $\leq 0,51 \mu\text{m Ra}$  – SF1.

External: as casted.

Other surface conditions see TIS.GIA – General information ADCAPure.

Ultrasonic cleaning.

**OPTIONS:**

- Different sealing materials.
- Degreased for oxygen use.
- Cavity fillers.
- Lever with locking system.

For more options and extras, consult IS M3H.100 – Sanitary Ball Valves Additional Options and Extras.

**USE:** Clean steam, gases and liquids compatible with the construction.

**AVAILABLE MODELS:** M3H – investment casting.

**SIZES:** 2 1/2" to 4"; DN 65 to DN 100.

**CONNECTIONS:** ASME BPE, DIN or ISO clamp ferrules, tube weld (ETO) ends or a combination of both. Others on request.

**PACKAGING:** Assembling and packaging in a clean room certified according to ISO 14644-1. The product is end capped and sealed with recyclable thermo-shrinkable plastic film, to avoid contamination.

**INSTALLATION:** See IMI – Installation and maintenance instructions.



**CE MARKING – GROUP 2  
(PED - EUROPEAN DIRECTIVE)**

PN 40	CATEGORY
2 1/2" to 4" – DN 65 to 100	1 (CE marked)

**PRESSURE / TEMPERATURE LIMITS**

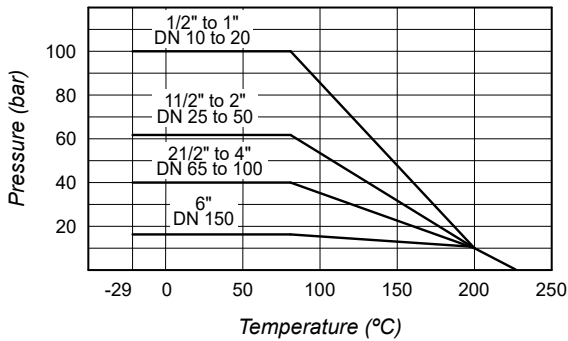

— Modified PTFE

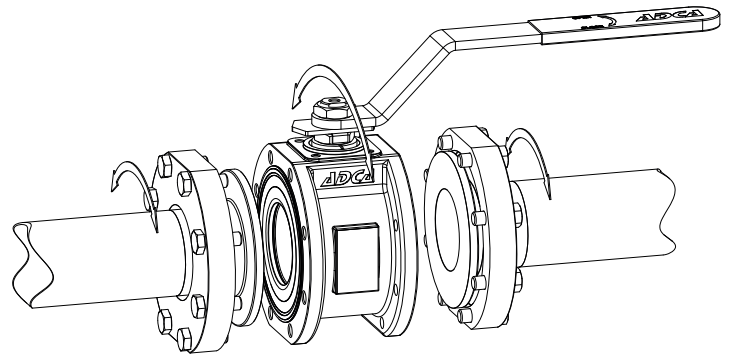

*Tube weld easy and quick installation*

Remark: Maximum operating conditions may be limited by the valve end connections due to normative restrictions.

Valves with tube weld (ETO) connections are fitted, as standard, with loose body flanges which allow installation with no need to align the end connections. After installation the valve can rotate freely 360° to the desired orientation.

LEVER OPTIONS	
FLAT LEVER	FLAT LEVER WITH LOCKING SYSTEM

STEM EXTENSION UNITS *		
SEF/H	SEF/P	SEF/A

\* Consult IS M3H.100 – Sanitary Ball Valves Additional Options and Extras – for further information.

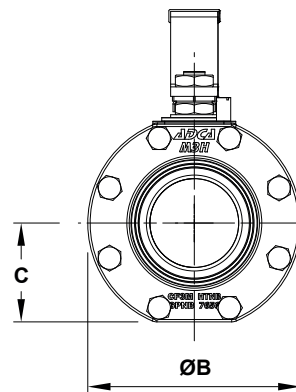
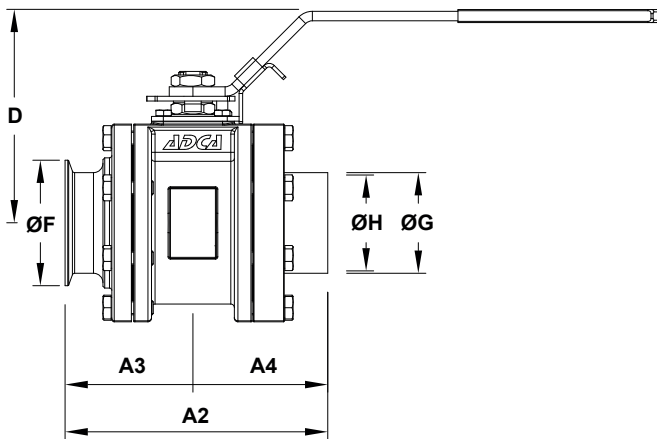
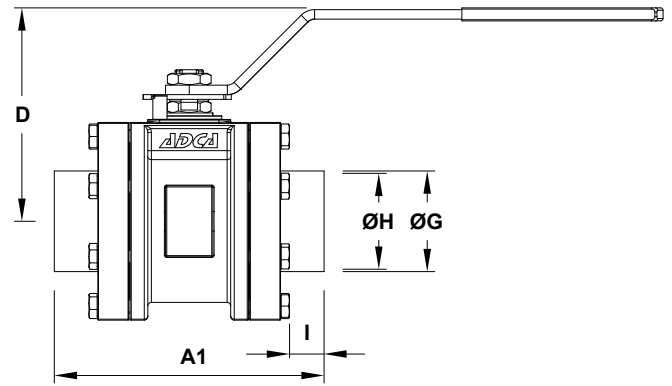
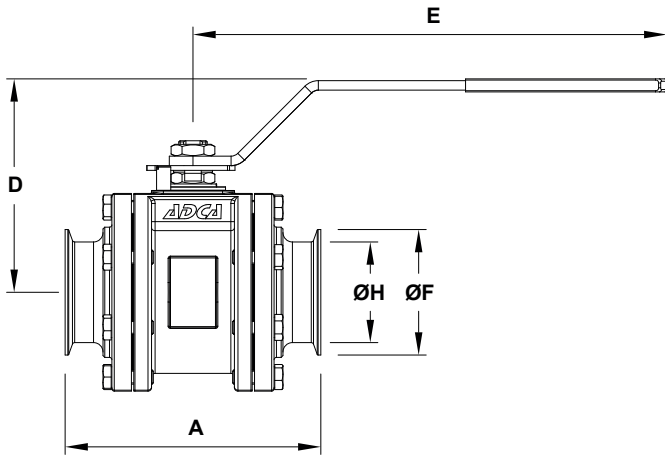

**DIMENSIONS – ASME BPE (mm)**

SIZE	A	A1	A2	A3	A4	ØB	C	D	E	ØF	ØG	ØH	I	BALL PORT	ISO 5211	WGT. (kg)
2 1/2"	190	203	196,3	95	101,5	160	72,5	169	394	77,4	63,5	60,2	37	60,2	F7	13,3
3"	216	228	222	108	114	180	83,5	180	394	90,9	76,2	72,9	38	72,9	F7	18,6
4"	254	267	260,5	127	133,5	220	101,5	198	394	118,9	101,6	97,4	44	97,4	F10	29,6

**DIMENSIONS – DIN (mm)**

SIZE	A	A1	A2	A3	A4	ØB	C	D	E	ØF	ØG	ØH	I	BALL PORT	ISO 5211	WGT. (kg)
65	190	203	197	95	101,5	160	72,5	169	394	91	70	66	37	62	F7	13,3
80	216	228	222	108	114	180	83,5	180	394	106	85	81	38	75	F7	18,6
100	255	267	261	127,5	130,5	220	101,5	198	394	119	104	100	44	98	F10	29,6

**DIMENSIONS – ISO (mm)**

SIZE	A	A1	A2	A3	A4	ØB	C	D	E	ØF	ØG	ØH	I	BALL PORT	ISO 5211	WGT. (kg)
65	-	203	-	-	101,5	160	72,5	169	394	91	76,1	72,1	37	62	F7	13,3
80	-	228	-	-	114	180	83,5	180	394	106	88,9	84,3	38	75	F7	18,6
100	-	267	-	-	130,5	220	101,5	198	394	119	114,3	109,7	44	98	F10	29,6

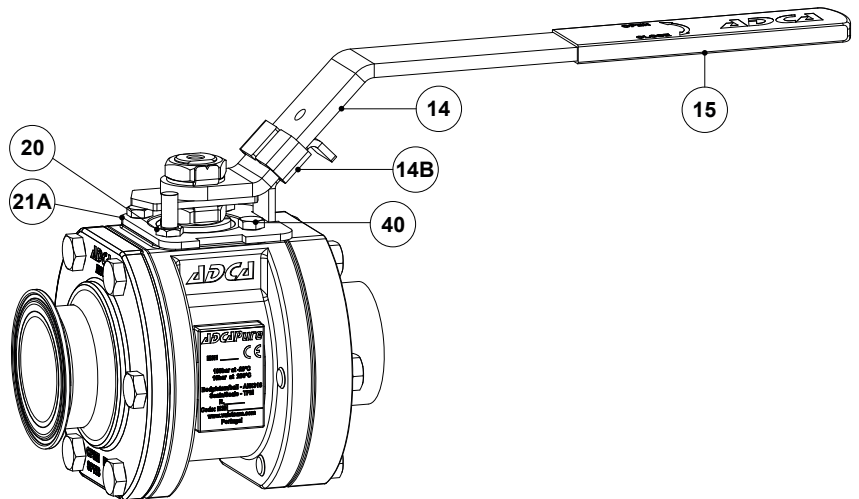
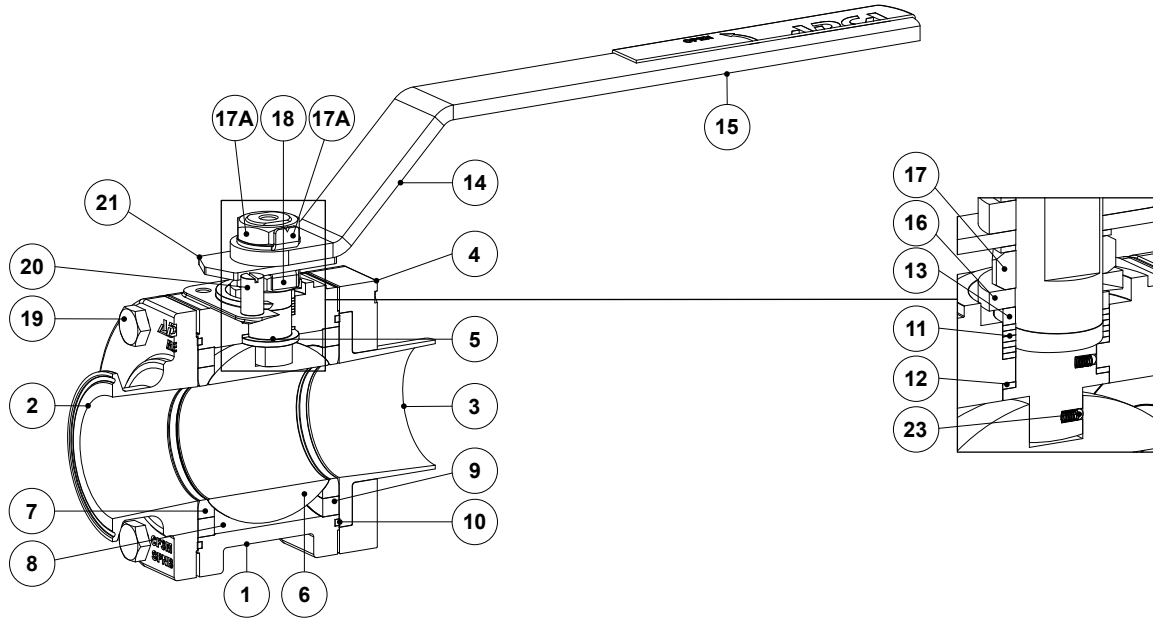

Optional flat lever with locking system

### MATERIALS

POS. No.	DESIGNATION	MATERIAL	POS. No.	DESIGNATION	MATERIAL
1	Valve body	A351 CF3M / 1.4409	14B	Locking piece	AISI 304 / 1.4301
2	Clamp ferrule end connection	A351 CF3M / 1.4409	15	Handle end	Vinyl
3	Tube weld end connection	AISI 316L / 1.4404; AISI 316L / 1.4435	16	Spring washer	Stainless steel A2
4	Flange	A351 CF8M / 1.4408	17	Compression nut	AISI 304 / 1.4301
5	Stem	AISI 316L / 1.4404	17A	Nut	AISI 304 / 1.4301
6	* Valve ball	AISI 316L / 1.4404	17B	* Lock washer	AISI 304 / 1.4301
7	* Standard seat	Modified PTFE	18	Lock washer	AISI 304 / 1.4301
8	* Cavity filler seat	Modified PTFE	19	Body fixing bolt	Stainless steel A2-70
9	Body ring	AISI 316L / 1.4404	20	Stop pin	AISI 304 / 1.4301
10	* Body seal	PTFE	21	Handle stopper	AISI 304 / 1.4301
11	* Stem seal	Modified PTFE	21A	Locking flange	AISI 304 / 1.4301
12	* Stem thrust seal	Modified PTFE	23	Antistatic device	AISI 316 / 1.4401
13	* Spacer	AISI 316 / 1.4401	40	Fixing bolt	Stainless steel A2-70
14	Handle	AISI 304 / 1.4301			

\* Available spare parts.

Remarks: FDA / USP Class VI seals certificate on request.

All valves have a serial number. In case of non-standard valves, this number must be supplied if spare parts are ordered.



ORDERING CODES M3H												
VALVE MODEL	MH	X	X	X	F	X	X	CB	X	65	E	
M3H – A351 CF3M / 1.4409 Three pieces ball valve	MH											
LEVER HANDLE												
Flat lever in stainless steel with plastic cover		X										
Flat lever in stainless steel with plastic cover and locking system		3										
Bare stem		9										
MATERIAL												
A351 CF3M / 1.4409			X									
A351 CF3M / 1.4409 with end connections in AISI 316L / 1.4435 (a)			G									
SEAT DESIGN												
Standard seats					X							
Cavity fillers					F							
SEAT MATERIAL												
Modified PTFE					F							
SURFACE FINISH (b)												
Standard surface finish							X					
Electropolished internal wetted parts (SF5)							E					
SPECIAL FEATURES												
None								X				
Degreased for oxygen								O				
PIPE CONNECTIONS												
Clamp ferrule ASME BPE									CB			
Clamp ferrule DIN (DIN 32676-A)									CD			
Tube weld (ETO) according to ASME BPE									TB			
Tube weld (ETO) according to DIN 11866-A (DIN 11850-2)									TD			
Tube weld (ETO) according to DIN 11866-B (ISO 1127)									TI			
TC/ETO combination ASME BPE									CTB			
TC/ETO combination DIN 32676-A / DIN 11866-A									CTD			
Ball port												
True bore (ASME BPE) or full bore (DIN and ISO)										X		
SIZE												
2 1/2" or DN 65											65	
3" or DN 80											80	
4" or DN 100											100	
SPECIAL CONSTRUCTION / ADDITIONAL OPTIONS												
Full description or additional codes have to be added in case of a non standard combination											E	

(a) Only available with tube weld (ETO) ends.

(b) Consult TIS.GIA – General information ADCAPure – for further details and other surface finish options.