

TWO-WAY GLOBE CONTROL VALVES V25/2 (ASME)

DESCRIPTION

The ADCATrol V25/2 is a series of single seated, two-way globe valves designed for process engineering and industrial applications, where events such as erosion, cavitation or flashing may occur. These valves can be assembled with pneumatic, hydraulic or electric actuators, for modulating and shut-off control tasks.

MAIN FEATURES

Robust construction.
Modular design to meet process requirements.
Stainless steel trim.

OPTIONS AND

ACCESSORIES: Bonnet extension for high and low temperatures.
Various stem sealing options including bellows sealing.
Soft, stellite and high-performance metal valve sealing.
V-port guided and perforated plugs.
Low noise, anti-cavitation single and multi-stage trims.
Reduced bore trims including microflow.
Pressure balancing trims.
Silencers.

USE: Saturated and superheated steam.
Hot and superheated water.
Air, gases and others.

AVAILABLE

MODELS: V25/2S – carbon steel.

VALVE SIZES: 1/2" to 6".

CONNECTIONS: Flanged ASME B16.5 Class 150 or 300.



CE MARKING – GROUP 2 (PED – European Directive)



Class 150	Class 300	Category
1/2" to 2"	1/2" to 1"	SEP
2 1/2" to 6"	1 1/2" to 4"	1 (CE marked)
–	6"	2 (CE marked)

BODY LIMITING CONDITIONS *

CLASS 150		CLASS 300	
ALLOWABLE PRESSURE	RELATED TEMPERATURE	ALLOWABLE PRESSURE	RELATED TEMPERATURE
19,3 bar	-10 °C / 50 °C	50 bar	-10 °C / 50 °C
15,8 bar	150 °C	43,9 bar	200 °C
12,1 bar	250 °C	36,9 bar	350 °C
8,4 bar	350 °C	34,6 bar	400 °C

* Rating according to EN 1759-1:2004.

BONNET DESIGN

STANDARD	EXTENDED
 <p data-bbox="363 631 526 660">-10 °C to 250 °C</p>	 <p data-bbox="1077 631 1209 660">Above 250 °C</p>

TRIM DESIGN

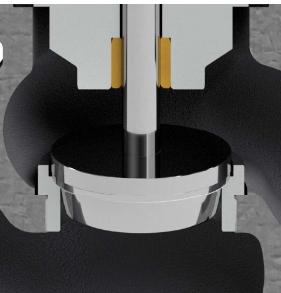
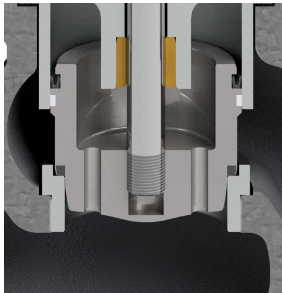
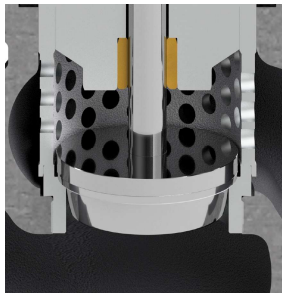
UNBALANCED TRIM	BALANCED TRIM	LOW NOISE (FD1)
		

STEM SEALING

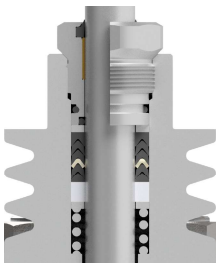
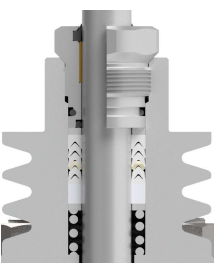
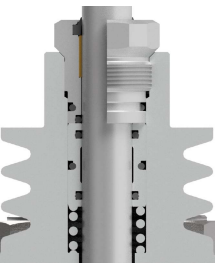
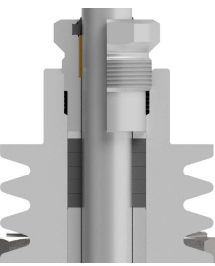
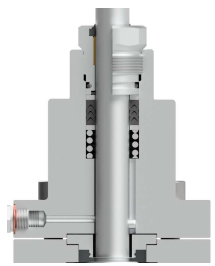
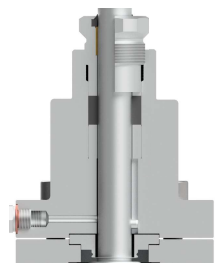
PTFE/GR V-RINGS (V1.2)	PTFE V-RINGS (V2.2)	EPDM (EP1)	GRAPHITE (G1)	BELLOWS	
				(BV1)	(BG1)
 <p data-bbox="127 1585 295 1615">-10 °C to 220 °C</p>	 <p data-bbox="359 1585 518 1615">-10 °C to 180 °C</p>	 <p data-bbox="585 1585 745 1615">-10 °C to 150 °C *</p>	 <p data-bbox="812 1585 971 1615">-10 °C to 400 °C</p>	 <p data-bbox="1045 1585 1204 1615">- 60 °C to 220 °C **</p>	 <p data-bbox="1284 1585 1444 1615">- 60 °C to 400 °C **</p>

* Up to 180 °C in steam and hot water applications; ** Maximum operating pressure: 25 bar.

PLUG DESIGN

PARABOLIC

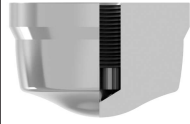

Sealing: Metal to metal
Characteristic: Equal percentage (EQP) or linear (PL)
Flow direction: From below
Rangeability: 50:1 (EQP) or 30:1 (PL)
Leakage: Class IV or Class V, acc. to IEC 60534-4

PARABOLIC (SOFT SEALING)



Sealing: PTFE/GR
Characteristic: Equal percentage (EQP) or linear (PL)
Flow direction: From below
Rangeability: 50:1 (EQP) or 30:1 (PL)
Leakage: Class VI, acc. to IEC 60534-4
Max. temp.: 200 °C

PERFORATED



Sealing: Metal to metal
Characteristic: Equal percentage (EQP) or linear (PL)
Flow direction: From above (liquids) or from below (gases)
Rangeability: 40:1 (EQP) or 30:1 (PL)
Leakage: Class IV, acc. to IEC 60534-4

PARABOLIC MICROFLOW



Sealing: Metal to metal
Characteristic: Linear (PL)
Flow direction: From below
Rangeability: 30:1
Leakage: Class IV or Class V, acc. to IEC 60534-4

V-PORT GUIDED

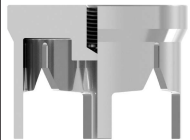

Sealing: Metal to metal
Characteristic: Equal percentage (EQP) or linear (PL)
Flow direction: From below
Rangeability: 30:1
Leakage: Class IV or Class V, acc. to IEC 60534-4

V-PORT GUIDED (SOFT SEALING)



Sealing: PTFE/GR *
Characteristic: Equal percentage (EQP) or linear (PL)
Flow direction: From below
Rangeability: 30:1
Leakage: Class VI, acc. to IEC 60534-4

* In soft sealing valves with seat Ø125 mm to Ø150 mm the PTFE/GR insert is placed on the seat rather than on the valve plug.

FLOW RATE COEFFICIENTS – PARABOLIC AND V-PORT GUIDED PL AND EQP PLUGS

SIZE	Kvs (m³/h)																			
	0,1 *	0,16 *	0,25 *	0,5 *	1	1,7	2,1	2,7	4	6,3	10	16	25	40	63	100	160	240	370	
1/2"	•	•	•	•	•	•	•	•	•											
3/4"	•	•	•	•	•	•	•	•	•	•										
1"	•	•	•	•	•	•	•	•	•	•	•									
1 1/2"										•	•	•	•							
2"											•	•	•	•						
2 1/2"												•	•	•	•					
3"													•	•	•	•				
4"														•	•	•	•			
6"																•	•	•	•	•
SEAT Ø (mm)	4				8		12		15	19,2	25	32	38	48	65	76	96	125	150	
STROKE (mm)	20														30			50		

* Microflow only available with linear characteristic.

FLOW RATE COEFFICIENTS – PERFORATED PL PLUGS

SIZE	Kvs (m³/h)											
	2,5	4	6,3	10	25	36	50	63	120	180	300	
1/2"	•											
3/4"	•	•										
1"	•	•	•									
1 1/2"		•	•	•	•							
2"			•	•	•	•						
2 1/2"				•	•	•	•					
3"					•	•	•	•				
4"						•	•	•	•			
6"								•	•	•	•	•
SEAT Ø (mm)	15	19,2	25	32	38	48	65	76	96	125	150	
STROKE (mm)	20						30			50		

FLOW RATE COEFFICIENTS – PERFORATED EQP PLUGS

SIZE	Kvs (m³/h)											
	2,5	4	6,3	10	16	25	36	50	80	120	250	
1/2"	•											
3/4"	•	•										
1"	•	•	•									
1 1/2"		•	•	•	•							
2"			•	•	•	•						
2 1/2"				•	•	•	•					
3"					•	•	•	•				
4"						•	•	•	•			
6"								•	•	•	•	•
SEAT Ø (mm)	15	19,2	25	32	38	48	65	76	96	125	150	
STROKE (mm)	20						30			50		

For conversion Kvs = Cv (US) x 0,865.

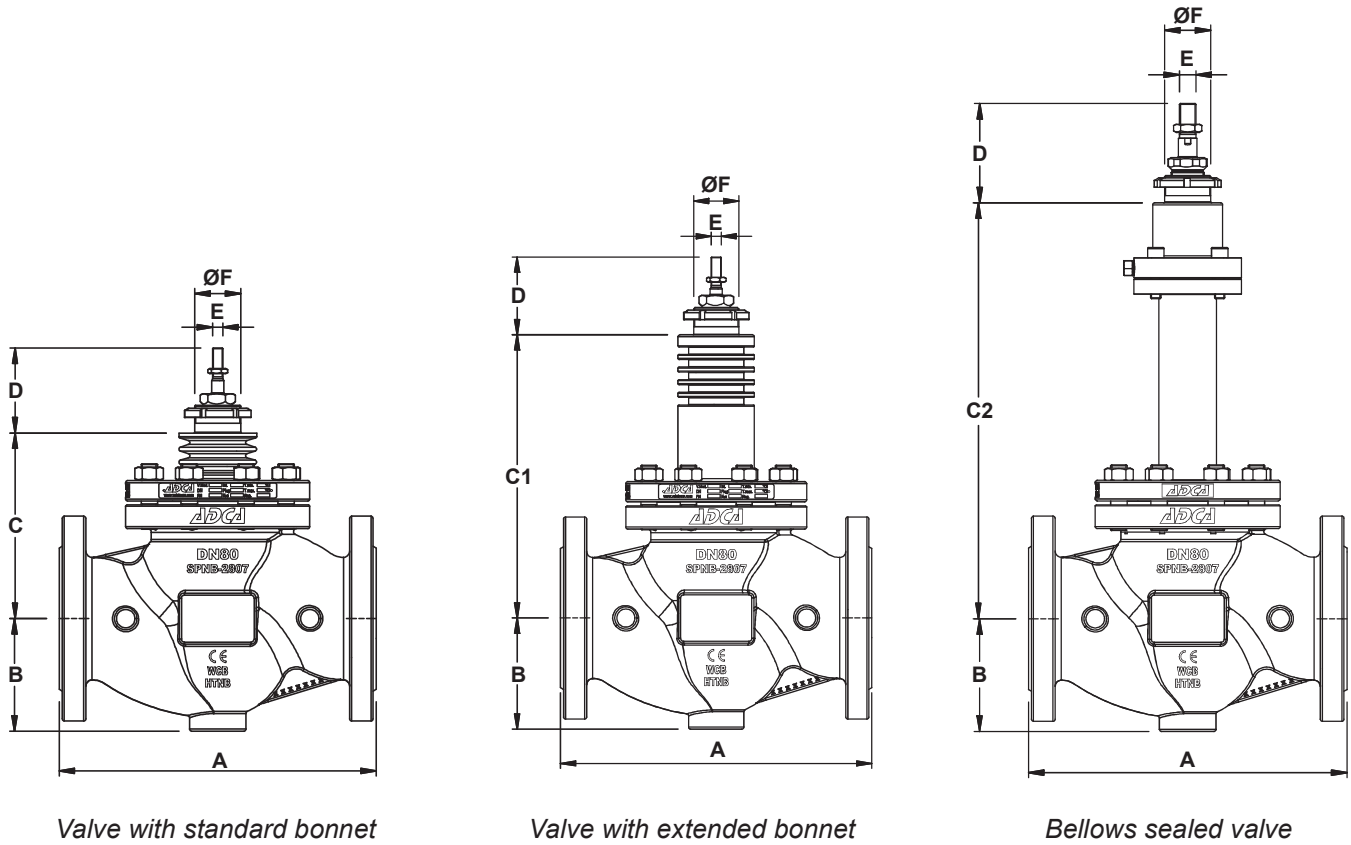

Valve with standard bonnet

Valve with extended bonnet

Bellows sealed valve

DIMENSIONS (mm)											
DIMENSION		SIZE									
		1/2"	3/4"	1"	1 1/2"	2"	2 1/2"	3"	4"	6"	
A	CLASS 150	184 a)	184 a)	184	222	254	276	298	352	451	
	CLASS 300	190 a)	194 a)	197	235	267	292	318	368	473	
B	CLASS 150	44,5	49	54	65	85	100	110	130	182	
	CLASS 300	47,5	58,5	62	78	85	100	110	130	182	
C		85	85	90	115	125	176	175	190	216	
C1		150	150	170	195	204	276	275	310	320	
C2		314	314	322	317	317	415	442	451	590	
D		77					92				110
E		M10 x 1					M16 x 1,5				
ØF		M40 x 1,5					M45 x 1,5			M65 x 2	

a) With welded-on flanges.

Remark: In the beginning of year 2022 new face to face dimensions have been defined for some Class 150 valves. Valves may still be supplied with the previous face to face dimensions under request. Consult the manufacturer.

WEIGHTS (kg)										
		SIZE								
		1/2"	3/4"	1"	1 1/2"	2"	2 1/2"	3"	4"	6"
STANDARD	CLASS 150	4,5	5	6,1	11,1	15,2	30,9	36,5	52,5	103,1
	CLASS 300	4,9	6	7,5	13,9	17,5	34	41,9	60,5	119,3
EXTENDED	CLASS 150	5,2	5,7	6,8	12,4	16,4	31,6	37	53,2	109,8
	CLASS 300	5,6	6,7	8,2	15,2	18,7	34,7	42,5	61,2	121,1
BELLOWS	CLASS 150	8,7	9,2	10,2	15,1	19	34,7	39,5	55,6	114,8
	CLASS 300	9,1	10,2	11,6	17,9	21,3	37,8	45,5	63,5	126,1

MAX. PERMISSIBLE ACTUATING THRUSTS (kN)										
MAX. THRUST	SIZE									
	1/2"	3/4"	1"	1 1/2"	2"	2 1/2"	3"	4"	6"	
	12					32,5			40,1	

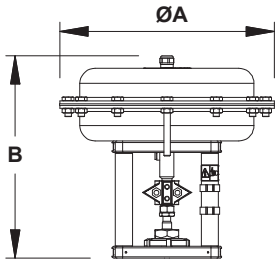

DIMENSIONS – PA SERIES PNEUMATIC ACTUATORS (mm)										
DIMENSION	PA10	PA206	PA25	PA281	PA40	PA341	PA436	PA80	PA80D	PA80T
ØA	170	209	250	275	300	336	430	405	405	405
B	251	236	260	243	325 / 360	323	351 / 371 *	505 / 515 / 545	741 / 771	967
WEIGHT (kg)	6,3	6,2	10,1	9,6	18,7	14,3	24,4 / 28 *	50,4 / 55,4 / 60	108 / 112	166

* For actuators with spring ranges 1 to 2 bar, 1,5 to 3 bar and 2 to 4 bar.
For more information, please consult IS 3.70 and IS 3.70A – PA Linear pneumatic actuators.

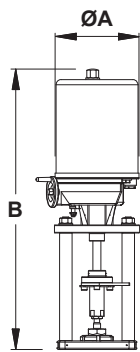

DIMENSIONS – EL SERIES ELECTRIC ACTUATORS (mm)						
DIMENSION	EL12	EL20	EL45	EL80	EL120	EL250
ØA	129	148	148	188	188	216
B	333	485	485	587	587	683
WEIGHT (kg)	2,1	8	8	13	13	19

For more information, please consult IS 3.72 – EL Linear electric actuators.

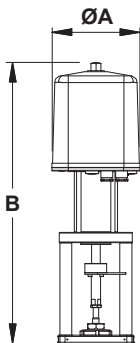

DIMENSIONS – ELR SERIES ELECTRIC ACTUATORS (mm)			
DIMENSION	ELR2.1	ELR2.2	ELR2.3
ØA	162	162	162
B	518 / 555 *	536 / 573 *	557 / 593 *
WEIGHT (kg)	8,7	9,3	10

* With PEL electronic positioner.
For more information, please consult IS 3.73 – ELR Linear electric actuators fail safe.

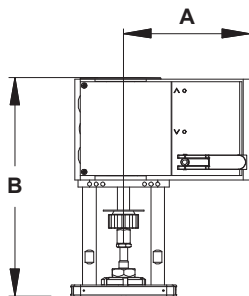

DIMENSIONS – AV SERIES ELECTRIC ACTUATORS (mm)		
DIMENSION	AVM234S	AVF234S
A	166	166
B	314	314
WEIGHT (kg)	4,1	4,1

For more information, please consult IS 3.74 – AVM234S-AVF234S Linear electric actuators.

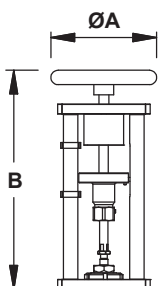

DIMENSIONS – MANUAL OPERATION HANDWHEEL (mm)	
DIMENSION	MAH
ØA	160
B	331
WEIGHT (kg)	5,6

MATERIALS

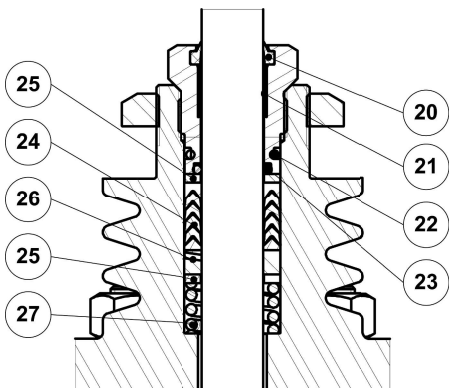
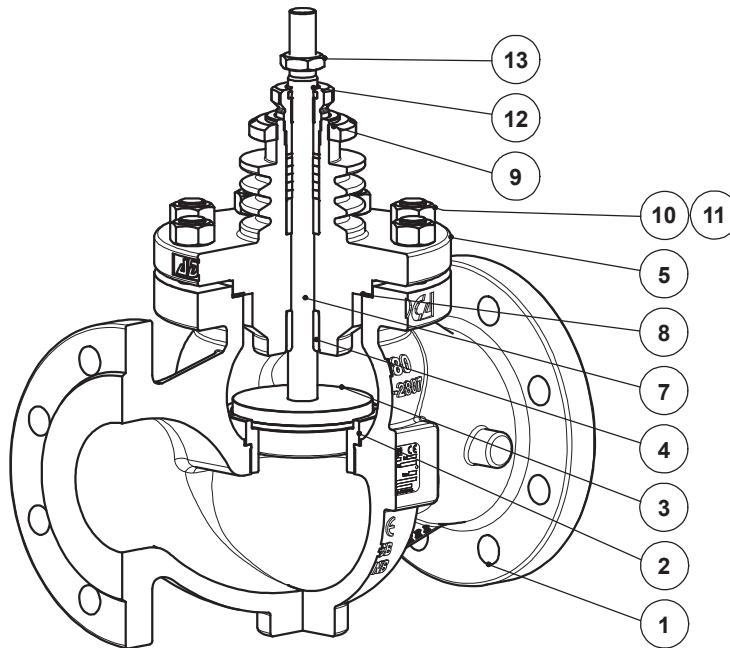

PTFE/GR V-Rings
(V1.2)

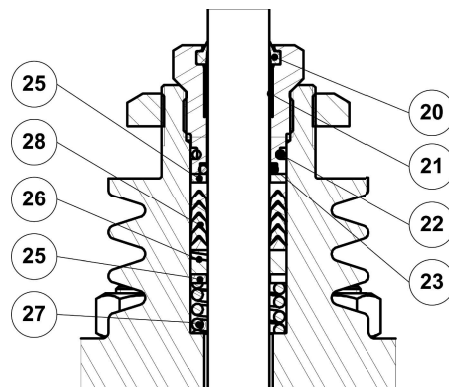

PTFE V-Rings
(V2.2)

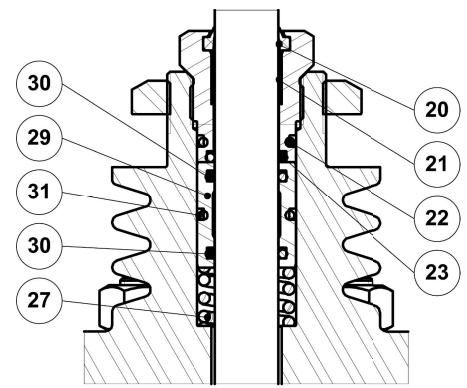

EPDM
(EP1)

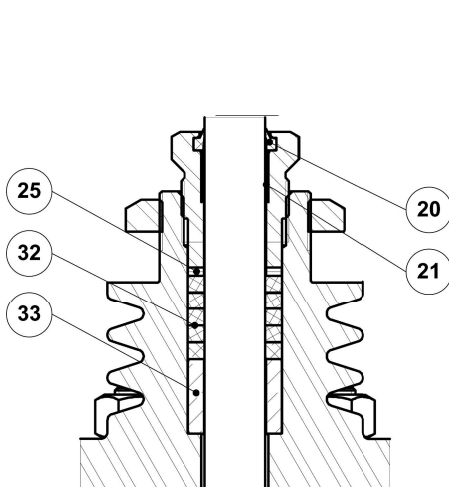

Graphite
(G1)

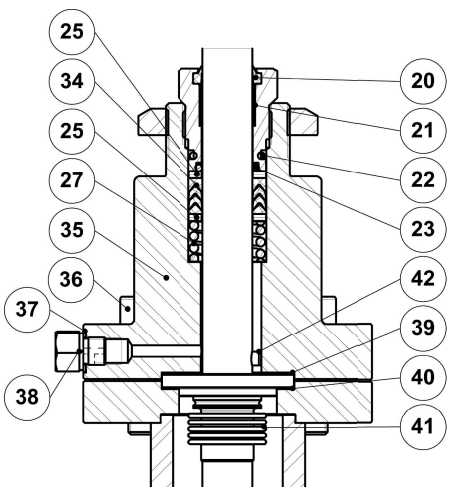

Bellows sealing
(BV1)

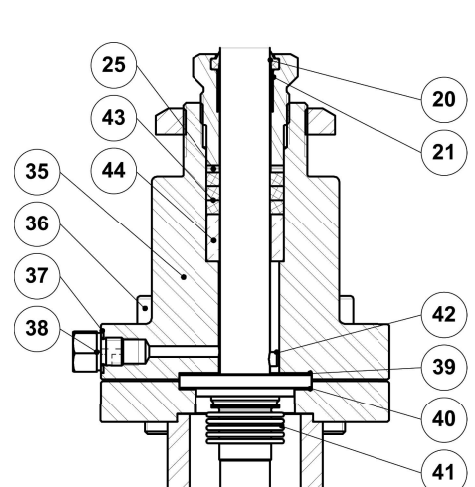

Bellows sealing
(BG1)

MATERIALS

POS. N°	DESIGNATION	MATERIAL
1	Valve body	A216 WCB / 1.0619
2	* Seat	AISI 316L / 1.4404
3	* Valve plug	AISI 316L / 1.4404
4	Stem guide	Bronze CB1
5	Bonnet	A351 CF8M / 1.4408; A216 WCB / 1.0619
7	* Stem	AISI 316 / 1.4401
8	* Gasket	Stainless steel / Graphite
9	Lock nut	A351 CF8 / 1.4308
10	Nuts	EN 10269 steel
11	Studs	EN 10269 steel
12	* Packing nut	AISI 303 / 1.4305
13	Lock nut	AISI 302 / 1.4310
20	* Scraper ring	Viton; NBR
21	* Plain bearing	Bronze / PTFE
22	* O-ring	EPDM
23	* O-ring	Viton
24	* Chevron packing set	PTFE
25	Washer	AISI 304 / 1.4301
26	* Stem guide	Stainless steel filled PTFE
27	* Spring	AISI 302 / 1.4310
28	* Chevron packing set	PTFE; Graphite filled PTFE
29	O-ring guide	AISI 304 / 1.4301
30	* O-ring	EPDM
31	* O-ring	EPDM
32	* Packing set	Expanded graphite
33	* Packing spacer	AISI 304 / 1.4301
34	* Safety packing set	Graphite filled PTFE
35	Bellows bonnet	A105 / 1.0432; AISI 316 / 1.4401
36	Bolts or studs and nuts	EN 10269 steel
37	Gasket	Copper
38	Compression fitting	AISI 316 / 1.4401
39	* Gasket	Stainless steel / Graphite
40	* Gasket	Stainless steel / Graphite
41	* Metal bellows	AISI 316Ti / 1.4571
42	* Locking pin	AISI 303 / 1.4305
43	* Safety packing set	Expanded graphite
44	Packing spacer	AISI 304 / 1.4301

* Available spare parts.

ORDERING CODES V25/2 a)														
Valve model	V2	2	S	S	1	U	1	1	1	E	FD	L	015	
Globe control valve, two-way, straight body	V2													
Valve series														
Series 2		2												
Body material														
A216 WCB / 1.0619 carbon steel			S											
Bonnet design														
Standard				S										
Extended					E									
Trim design														
Unbalanced trim					1									
Balanced trim					2									
Unbalanced trim with FD1 low noise cage					3									
Balanced trim with FD1 low noise cage					4									
Flow direction														
Flow under the plug						U								
Flow over the plug							O							
Stem sealing														
PTFE/GR V-Rings (V1.2)								1						
Virgin PTFE V-Rings (V2.2)								2						
Graphite (G1)								3						
EPDM (EP1)								4						
Stainless steel bellows with PTFE/GR safety packing (BV1)								8						
Stainless steel bellows with graphite safety packing (BG1)								9						
Plug design														
Parabolic									1					
V-port guided (standard for size 6")									2					
Perforated									3					
Valve sealing														
Metal to metal (class IV)										1				
Metal to metal (class V)										2				
Soft sealed with PTFE/GR (class VI)										3				
Stellited (class IV)										4				
Characteristic														
Equal percentage (EQP)											E			
Linear (PL)											L			
Flow rate coefficient														
Kvs 4												FD		
See table below for other Kvs value codes														
Pipe connection														
Flanged ASME B16.5 Class 150													U	
Flanged ASME B16.5 Class 300													V	
Size														
1/2"														015
3/4"														020
...														
Special valves / Extras														
Full description or additional codes have to be added in case of a non-standard combination														E

a) Codification for valve only. For actuator codes, refer to the appropriate information sheet.

FLOW RATE COEFFICIENT CODES														
Kvs	0,1	0,16	0,25	0,5	1	1,7	2,1	2,5 *	2,7	4	6,3	10	16	25
Code	M4	M3	M2	M1	R4	R3	R2	PA	R1	FD	FE	FF	FG	FH
Kvs	36 *	40	50 *	63	80 *	100	120 *	160	180 *	240	250 *	300 *	370	-
Code	PB	FI	PC	FJ	PD	FL	PE	FM	PF	FN	PG	PH	FO	-

* Only available with perforated plug design.