

Type test approved safety valves angle-type for industrial applications

3.8

642

Safety valves made of gunmetal, angle-type with threaded or flange connections

→ Series 642



■ SUITABLE FOR

Liquids	neutral and non-neutral	
Air, gases and vapours	neutral and non-neutral	
Steam		

■ EXAMPLES OF USE

For the protection of:

- Pressure-vessels/-systems for neutral / non-neutral vapours, gases and liquids
- Steam boilers and steam plants taking into account the plant-specific regulations and making use of the suitable valve versions and sealing materials.

- Mechanical engineering
- pump protection
- Pressure booster systems water- / air-side
- cooling-/chilling-systems
- Steam- and industrial-boiler systems

Safety valves are set and sealed at the factory.

■ APPROVALS

TÜV Type test approval 2072, 2102	D/G,F
EC type examination	S/G, L
ASME	S, G, L
CRN	S, G, L
TSG ZF001 - 2006	D/G (S/G), F (L)
KGS	G
Type approval ACS	
Type approval WRAS	
TR ZU 032/2013 - TR ZU 010/2011	D/G (S/G), F (L)
Requirements	
AD 2000 Data sheet A2	TRD 421
DIN EN ISO 4126-1	ASME-Code Sec. VIII Div. 1
PED 2014/68/EU	KGS AA 319

■ Classification society

DNVGL	DNVGL
Bureau Veritas	BV
Lloyd's Register EMEA	LR EMEA
Russian Maritime Register of Shipping	RMRS
American Bureau of Shipping	ABS
Registro Italiano Navale	RINA



■ MATERIAL



■ SPECIFICATION



1/2" – 2 1/2"



– 50°C to + 205°C depending on version



0,5 – 16 bar



DN 25 – DN 65

■ MATERIALS

Component	Material	DIN EN	ASME
Inlet body	Gunmetal	CC499K	CC499K
Outlet body	Gunmetal	CC499K	CC499K
Internal parts	Brass	CW617N	CW617N
Internal wetted parts	Dezincification resistant brass	CW602N	CW602N
	Stainless steel	1.4404	316L
Spring	Stainless steel	1.4310	302

m	Standard with diaphragm	The diaphragm prevents the medium entering into the spring housing and protects moving parts from being affected by the medium.
----------	-------------------------	---

■ MEDIUM

GF	gaseous and liquid	Air, vapours, gases, liquids and - depending on seal - also for steam
-----------	--------------------	---

■ TYPE OF LIFTING MECHANISM

L	Lifting lever
0	without lifting device

■ AVAILABLE NOMINAL DIAMETERS AND CONNECTION SIZES

Nominal diameter DN	15	20	25	32	40	50	65
Inlet	1/2" (15)	3/4" (20)	1" (25)	1 1/4" (32)	1 1/2" (40)	2" (50)	2 1/2" (65)
Outlet	1/2" (15)	■					
	3/4" (20)		■				
	1" (25)			■			
	1 1/4" (32)				■		
	1 1/2" (40)					■	
	2" (50)						■
	2 1/2" (65)						

■ TYPE OF CONNECTION INLET / OUTLET

f / f	Standard	Female thread BSP-P / Female thread BSP-P	DIN EN ISO 228-1 / DIN EN ISO 228-1
FLDIN / f		Flange connection (from DN 25) / Female thread BSP-P	DIN EN ISO 228-1 / DIN EN ISO 228-1

■ SEAT SEALS / DIAPHRAGMS

PTFE / EPDM	Polytetrafluorethylen / Ethylen-Propylene-Diene (Standard)	Flat seal and moulded diaphragm	-50°C to +205°C
EPDM / EPDM	Ethylen-Propylene-Diene / Ethylen-Propylene-Diene	Flat seal and moulded diaphragm	-50°C bis +150°C
PTFE / FKM	Polytetrafluorethylen / Fluorcarbon	Flat seal and moulded diaphragm	-30°C to +200°C
FKM / FKM	Fluorcarbon / Fluorcarbon	Elastomere seals and moulded diaphragm	-20°C to +200°C

■ NOMINAL DIAMETERS, CONNECTIONS, INSTALLATION DIMENSIONS

Series 642: Connection, installation dimensions, ranges of adjustment									
Nominal diameter	DN	15	20	25	32	40	50	65	
Connection DIN EN ISO 228	G	1/2" (15)	3/4" (20)	1" (25)	1 1/4" (32)	1 1/2" (40)	2" (50)	2 1/2" (65)	
Connection DIN EN 1092-3	DN / PN	-	-	25 / 16	32 / 16	40 / 16	50 / 16	65 / 16	
Connection ANSI B 16.24	NPS / CLASS	-	-	1" / 150	1 1/4" / 150	1 1/2" / 150	2" / 150	2 1/2" / 150	
Outlet DIN EN ISO 228	G	1/2" (15)	3/4" (20)	1" (25)	1 1/4" (32)	1 1/2" (40)	2" (50)	2 1/2" (65)	
Installation dimensions in mm	L	35,5	42,5	45	48	58	68	80	
	Lmax	63	75	77	102	145	150	155	
	H	82	97	107	132	168	199	240	
	H1	90	106	120	150	192	229	276	
	Hmax	102	120	133	153	210	252	298	
	h	28	36	38	39	45	55	65	
	h1	-	-	60	66	73	83	96	
	D DIN / ANSI	-	-	115 / 110	140 / 115	150 / 125	165 / 150	185 / 180	
	d1 DIN / ANSI	-	-	65 / 50,8	76 / 63,5	84 / 73	99 / 92,1	118 / 104,8	
	SW	27	34	41	50	60	70	90	
	do	13	15	18	23	30	39	48	
	G1	-	-	1/4"	1/4"	1/4"	1/4"	1/4"	
	K / nxd (DIN)	-	-	85 / 4x14	100 / 4x18	110 / 4x18	125 / 4x18	145 / 4x18	
	K / nxd (ANSI)	-	-	79,4 / 4x15,9	88,9 / 4x15,9	98,4 x 4x15,9	120,7 / 4x19,1	139,7 / 4x19,1	
	Coefficients of flow ISO 4126-1	$\alpha_w / Kdr (F)$	0,41	0,39	0,43	0,43	0,38	0,38	0,38
		$\alpha_w / Kdr (D/G)^1$	0,6	0,56	0,63	0,63	0,55	0,55	0,55
Coefficients of flow ASME-Code Sec. VIII Div. 1	$\alpha_w / Kdr (F)$	0,43	0,43	0,43	0,43	0,36	0,36	0,36	
	$\alpha_w / Kdr (D/G)$	0,65	0,65	0,65	0,65	0,55	0,55	0,55	
Weight	kg	0,5	0,8	1,1	1,7	3,3	5,8	8,9	
	kg FLDIN / FLANSI	-	-	2,0 / 1,9	3,4 / 2,9	4,1 / 3,5	8,4 / 7,9	12,0 / 11,8	
Range of adjustment	bar	0,5 - 16	0,5 - 16	0,5 - 16	0,5 - 16	0,5 - 16	0,5 - 16	0,5 - 16	
Range of adjustment ASME	psi	15 - 232	15 - 232	15 - 232	15 - 232	15 - 232	15 - 232	15 - 232	

¹Coefficients of flow for blow-off pressures for blow-off pressures > 3,5 bar. For lower pressures refer to values in the capacity table.

■ MAIN DIMENSIONS, INSTALLATION DIMENSIONS

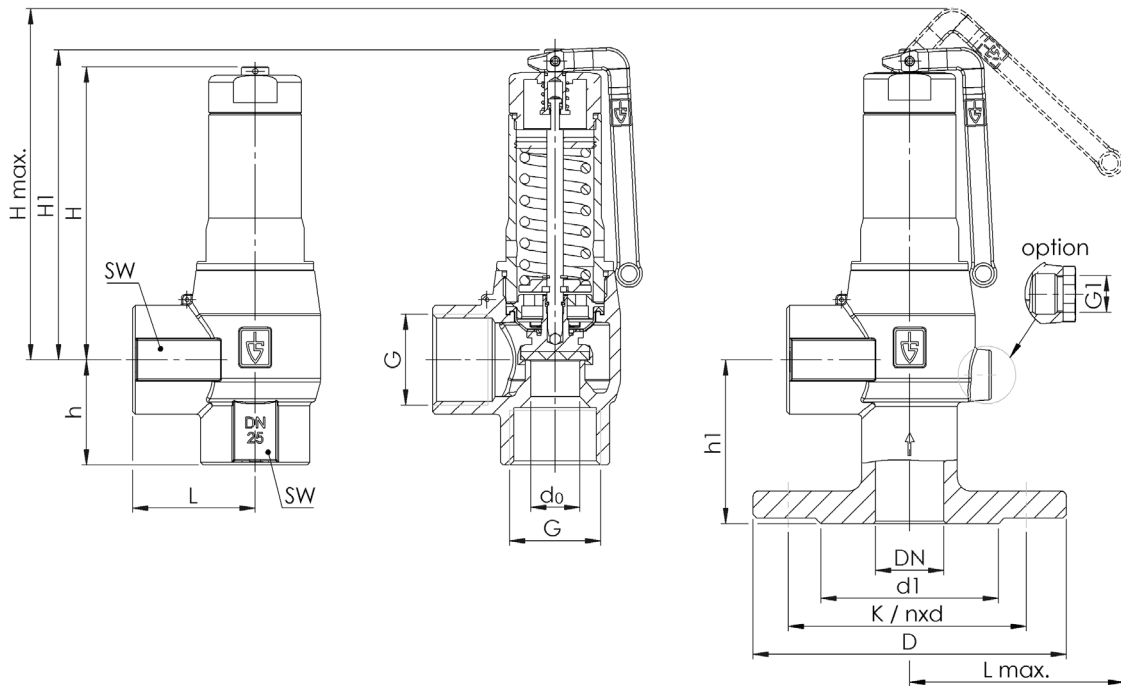

Series 642 ■ INDIVIDUAL SELECTION / VALVE CONFIGURATION

Series	Valve version	Medium	Lifting device	Nominal diameter DN	Connection type		Connection size		Seal	Options	Set pressure	Quantity
					Inlet	Outlet	Inlet	Outlet				
642	m	GF	L	15	f	f	15	15	PTFE / EPDM		6	2
642	m	GF	O	25	m	f	25	25	FKM / FKM		2	4
642	m	GF				f						
642	m	GF				f						

■ TECHNICAL FINISHES, VARIANTS, ACCESSORIES

A02	Connection for condensate in the outlet body	<input type="checkbox"/>
		<input type="checkbox"/>
		<input type="checkbox"/>

■ PROPERTIES

P01	Oil- and grease-free production	<input type="checkbox"/>	P03	Galvanically nickel-plated finish	<input type="checkbox"/>
P02	Chemically nickel-plated finish	<input type="checkbox"/>	P04	Chrome-plated finish	<input type="checkbox"/>
		<input type="checkbox"/>			<input type="checkbox"/>

■ CERTIFICATES / APPROVALS

C01	Factory certificate acc. DIN EN 10204 2.2 (WKZ 2.2)	<input type="checkbox"/>	C06	ATEX evaluation acc. to 2014/34/EU	<input type="checkbox"/>
C02	Test certificate acc. DIN EN 10204 3.1 (WPZ 3.1)	<input type="checkbox"/>	C07	SIL evaluation relating to IEC 61508-2	<input type="checkbox"/>
C03	Material test certificate acc. DIN EN 10204 3.1 (MPZ 3.1) (pressure retaining part)	<input type="checkbox"/>	C09	Seat tightness test with helium, leak detection method under vacuum incl. Factory Inspection Certificate 3.1 acc. to DIN EN 10204	<input type="checkbox"/>
C04	TÜV/DEKRA individual inspection acc. EN 10204 3.2 (TÜV/DEKRA-APZ)	<input type="checkbox"/>	C10	Certificate of oil- and grease free production	<input type="checkbox"/>
C05	Sealing material Manufacturer certification (FDA, USP 3, 3-A,...), Please indicate description of certificate:	<input type="checkbox"/>			<input type="checkbox"/>

■ ADMISSIONS / ACCREDITATIONS

AA1	EC Type examination acc. to Directive 2014/68/EU	<input type="checkbox"/>	AK1	Water regulations and advisory scheme WRAS type approval DNV-GL (DNVGL) type approval	<input type="checkbox"/>
AA2	TÜV component test acc. to VdTÜV specification sheet SV 100	<input type="checkbox"/>	AK2	Lloyd's Register (LR) type approval	<input type="checkbox"/>
AA3	Certification acc. to ASME Boiler and Pressure Vessel Code, Section VIII.Div 1 (ASME)	<input type="checkbox"/>	AK3	American Bureau of Shipping (ABS) type approval	<input type="checkbox"/>
AA4	EAC - certificate/declaration with passport for the valve and laser marking of the valve	<input type="checkbox"/>	AK4	Bureau Veritas (BV) type approval	<input type="checkbox"/>
AA5	Manufacture License of Special Equipment People's Republic of China (ML)	<input type="checkbox"/>	AK5	Russian Maritime Register of Shipping (RMRS) type approval	<input type="checkbox"/>
AA6	Certification acc. to. Korean Gas Safety Corporation (KGS)	<input type="checkbox"/>	AK6	Registro Italiano Navale (RINA) type approval	<input type="checkbox"/>
AA7	Registration according to Canadian Registration Number (CRN)	<input type="checkbox"/>	AL	Individual inspection by notified body inspector – (body to be indicated):	<input type="checkbox"/>
AB2	Water regulations and advisory scheme WRAS type approval	<input type="checkbox"/>			<input type="checkbox"/>

■ ENQUIRY

Copy and send to: order@goetze-armaturen.de.

Order form easily to be found online under the section for each series.

Series 642: Blowing-off rates at 10% above set pressure													
Nominal diameter DN		15 d0 = 13 mm			20 d0 = 15 mm			25 d0 = 18 mm			32 d0 = 23 mm		
	Set pressure bar	I	II	III	I	II	III	I	II	III	I	II	III
Air I Nm ³ /h	0,5	74	56	2,1	85	64	2,7	143	117	4,3	234	191	7,0
	1	106	84	2,9	124	97	3,7	207	165	5,8	338	269	9,5
	2	173	136	4,1	204	159	5,2	340	268	8,2	556	437	13,5
Steam II kg/h	3	233	181	5,0	279	217	6,4	468	365	10,1	764	595	16,5
	4	293	226	5,8	357	276	7,4	592	458	11,7	966	748	19,1
	5	352	272	6,5	438	338	8,2	712	549	13,1	1163	896	21,3
Water III m ³ /h	6	412	318	7,1	512	395	9,0	833	639	14,3	1359	1043	23,4
	7	471	364	7,7	586	452	9,7	953	729	15,5	1556	1190	25,2
	8	531	410	8,2	660	509	10,4	1074	819	16,5	1753	1337	27,0
	9	591	456	8,7	734	566	11,0	1194	908	17,5	1950	1483	28,6
	10	650	502	9,2	808	623	11,6	1315	998	18,5	2147	1629	30,2
	11	710	548	9,6	882	680	12,2	1435	1088	19,4	2343	1776	31,7
	12	770	594	10,1	956	738	12,7	1556	1177	20,2	2540	1922	33,1
	13	829	640	10,5	1030	795	13,3	1676	1266	21,1	2737	2068	34,4
	14	889	686	10,9	1104	852	13,8	1797	1356	21,9	2934	2214	35,7
	15	948	732	11,3	1178	909	14,3	1917	1446	22,6	3130	2361	37,0
	16	1008	778	11,6	1252	966	14,7	2038	1535	23,4	3327	2507	38,2

Series 642: Blowing-off rates at 10% above set pressure										
Nominal diameter DN		40 d0 = 30 mm			50 d0 = 39 mm			65 d0 = 48 mm		
	Set pressure bar	I	II	III	I	II	III	I	II	III
Air I Nm ³ /h	0,5	338	276	10,5	571	466	17,7	864	706	26,8
	1	491	392	14,3	831	662	24,1	1258	1003	36,5
	2	816	642	20,2	1379	1085	34,2	2089	1643	51,8
Steam II kg/h	3	1128	879	24,8	1907	1486	41,9	2888	2251	63,5
	4	1430	1107	28,7	2417	1872	48,4	3661	2835	73,4
	5	1721	1326	32,1	2909	2241	54,2	4407	3395	82,1
Water III m ³ /h	6	2013	1544	35,1	3402	2609	59,4	5153	3953	89,9
	7	2304	1762	37,9	3894	2977	64,1	5899	4510	97,1
	8	2595	1979	40,6	4386	3344	68,6	6644	5066	103,9
	9	2887	2196	43,0	4879	3711	72,7	7390	5621	110,2
	10	3178	2412	45,4	5371	4077	76,7	8136	6175	116,1
	11	3469	2629	47,6	5863	4443	80,4	8882	6730	121,8
	12	3761	2845	49,7	6356	4809	84,0	9627	7284	127,2
	13	4052	3061	51,7	6848	5174	87,4	10373	7837	132,4
	14	4343	3278	53,7	7340	5541	90,7	11119	8393	137,4
	15	4635	3495	55,6	7833	5907	93,9	11865	8948	142,3
	16	4926	3711	57,4	8325	6272	97,0	12611	9501	146,9

Series 642: Blowing-off rates at 10% above set pressure													
Nominal diameter DN		15			20			25			32		
		d ₀ = 0,5118 inch (13 mm)			d ₀ = 0,5906 inch (15 mm)			d ₀ = 0,7087 inch (18 mm)			d ₀ = 0,9055 inch (23 mm)		
Set pressure psi(g)		I	II	III	I	II	III	I	II	III	I	II	III
Air I SCFM	15	80,2	225,2	14,2	106,8	299,8	18,9	153,8	431,8	27,2	210,9	592,1	37,2
	30	117,0	328,5	19,2	155,8	437,4	25,6	224,3	629,8	36,9	307,6	863,8	50,4
	40	144,0	404,3	22,2	191,7	538,2	29,6	276,0	775,0	42,6	378,6	1063,0	58,2
	50	171,0	480,0	24,8	227,6	639,1	33,1	327,8	920,3	47,6	449,5	1262,1	65,1
	60	197,9	555,8	27,2	263,5	739,9	36,2	379,5	1065,5	52,2	520,5	1461,3	71,3
Steam II PPH	70	224,9	631,5	29,4	299,5	840,8	39,1	431,2	1210,8	56,3	591,4	1660,5	77,0
	80	251,9	707,3	31,4	335,4	941,7	41,8	483,0	1356,0	60,2	662,4	1859,7	82,3
	90	278,9	783,1	33,3	371,3	1042,5	44,4	534,7	1501,2	63,9	733,3	2058,9	87,3
Water III GPM	100	305,9	858,8	35,1	407,2	1143,4	46,8	586,4	1646,5	67,3	804,2	2258,1	92,0
	110	332,9	934,6	36,8	443,1	1244,2	49,1	638,1	1791,7	70,6	875,2	2457,3	96,5
	120	359,8	1010,3	38,5	479,1	1345,1	51,2	689,9	1936,9	73,8	946,1	2656,5	100,8
	130	386,8	1086,1	40,1	515,0	1446,0	53,3	741,6	2082,2	76,8	1017,1	2855,7	104,9
	140	413,8	1161,8	41,6	550,9	1546,8	55,3	793,3	2227,4	79,7	1088,0	3054,9	108,9
	150	440,8	1237,6	43,0	586,8	1647,7	57,3	845,0	2372,7	82,5	1159,0	3254,1	112,7
	160	467,8	1313,3	44,4	622,8	1748,5	59,2	896,8	2517,9	85,2	1229,9	3453,3	116,4
	170	494,7	1389,1	45,8	658,7	1849,4	61,0	948,5	2663,1	87,8	1300,9	3652,4	120,0
	180	521,7	1464,9	47,1	694,6	1950,3	62,7	1000,2	2808,4	90,4	1371,8	3851,6	123,5
	190	548,7	1540,6	48,4	730,5	2051,1	64,5	1052,0	2953,6	92,8	1442,7	4050,8	126,8
200	575,7	1616,4	49,7	766,4	2152,0	66,1	1103,7	3098,9	95,2	1513,7	4250,0	130,1	
210	602,7	1692,1	50,9	802,4	2252,8	67,8	1155,4	3244,1	97,6	1584,6	4449,2	133,3	
220	629,7	1767,9	52,1	838,3	2353,7	69,4	1207,1	3389,3	99,9	1655,6	4648,4	136,5	
230	656,6	1843,6	53,3	874,2	2454,6	70,9	1258,9	3534,6	102,1	1726,5	4847,6	139,5	
232	662,0	1858,8	53,5	881,4	2474,7	71,2	1269,2	3563,6	102,6	1740,7	4887,4	140,2	

Series 642: Blowing-off rates at 10% above set pressure										
Nominal diameter DN		40			50			65		
		d ₀ = 1,1811 inch (30 mm)			d ₀ = 1,5354 inch (39 mm)			d ₀ = 1,8898 inch (48 mm)		
Set pressure psi(g)		I	II	III	I	II	III	I	II	III
Air I SCFM	15	358,8	1007,4	63,3	606,4	1702,5	107,0	918,5	2579,0	162,1
	30	523,4	1469,5	85,7	884,5	2483,5	144,9	1339,9	3762,0	219,5
	40	644,1	1808,4	99,0	1088,5	3056,3	167,3	1648,9	4629,6	253,5
	50	764,8	2147,3	110,7	1292,5	3629,0	187,1	1957,9	5497,1	283,4
	60	885,5	2486,2	121,3	1496,5	4201,7	204,9	2266,9	6364,7	310,4
Steam II PPH	70	1006,2	2825,1	131,0	1700,5	4774,4	221,4	2575,8	7232,3	335,3
	80	1126,9	3164,0	140,0	1904,4	5347,1	236,6	2884,8	8099,8	358,5
	90	1247,6	3502,9	148,5	2108,4	5919,9	251,0	3193,8	8967,4	380,2
Water III GPM	100	1368,3	3841,8	156,5	2312,4	6492,6	264,6	3502,8	9834,9	400,8
	110	1489,0	4180,7	164,2	2516,4	7065,3	277,5	3811,8	10702,5	420,3
	120	1609,7	4519,5	171,5	2720,4	7638,0	289,8	4120,8	11570,0	439,0
	130	1730,4	4858,4	178,5	2924,3	8210,8	301,7	4429,8	12437,6	456,9
	140	1851,1	5197,3	185,2	3128,3	8783,5	313,0	4738,8	13305,2	474,2
	150	1971,8	5536,2	191,7	3332,3	9356,2	324,0	5047,7	14172,7	490,8
	160	2092,5	5875,1	198,0	3536,3	9928,9	334,7	5356,7	15040,3	506,9
	170	2213,2	6214,0	204,1	3740,3	10501,6	345,0	5665,7	15907,8	522,5
	180	2333,9	6552,9	210,0	3944,2	11074,4	355,0	5974,7	16775,4	537,7
	190	2454,6	6891,8	215,8	4148,2	11647,1	364,7	6283,7	17642,9	552,4
200	2575,3	7230,7	221,4	4352,2	12219,8	374,2	6592,7	18510,5	566,8	
210	2696,0	7569,5	226,9	4556,2	12792,5	383,4	6901,7	19378,0	580,8	
220	2816,7	7908,4	232,2	4760,2	13365,3	392,4	7210,7	20245,6	594,4	
230	2937,4	8247,3	237,4	4964,1	13938,0	401,2	7519,7	21113,2	607,8	
232	2961,5	8315,1	238,4	5004,9	14052,5	403,0	7581,4	21286,7	610,4	