

## PILOT OPERATED PRESSURE REDUCING VALVES PRV57 and PRS57

### DESCRIPTION

The ADCA PRV57 pilot operated pressure reducing valves are designed for use with steam, compressed air, nitrogen and other gases compatible with the construction materials.

The PRV57 can be installed in pressure reducing stations throughout all industries, and provide sensitive and accurate control even when inlet pressure fluctuations or relevant flow variations occur.

### MAIN FEATURES

Precise control of downstream pressures from 0,07 bar to 17 bar.

Robust steel or stainless steel construction.

Suitable for dead end conditions.

Guided piston and valve stem.

Hardened plug.

### OPTIONS:

- Soft sealing.
- Low pressure top.
- Dome loaded version.
- Bottom cover drain connection.
- Stellited plug and seat.
- Internal sensing line.

### USE:

Saturated steam, compressed air and other gases compatible with the construction (except oxygen).

### AVAILABLE MODELS:

- PRV57, PRV57E – steel versions for steam.
- PRV57i, PRV57iE – stainless steel versions for steam (only available from DN 15 to DN 50).
- PRV57G, PRV57GE – steel versions for compressed air and gases.
- PRV57Gi, PRV57GiE – stainless steel versions for compressed air and gases (only available from DN 15 to DN 50).
- Suffix E: Version with solenoid valve for remote closure.
- PRS: All models above are available with an optional sustaining valve pilot, e.g. PRS57G (see Fig. 8).

### SIZES:

DN 15 to DN 100.

### CONNECTIONS:

Flanged EN 1092-1 PN 16 or PN 40.  
Standard PN 16 DN 65 flanges are supplied with 4 holes. 8 holes, according to EN 1092-1, on request.

### INSTALLATION:

Horizontal installation, see IMI – Installation and maintenance instructions.  
In steam applications, a “Y” strainer, humidity separator and steam trap should be installed upstream of the valve.



#### CE MARKING – GROUP 2 (PED – European Directive)

PN 16	PN 40	Category
DN 15 to 50	DN 15 to 32	SEP
DN 65 to 100	DN 40 to 100	1 (CE Marked)

LIMITING CONDITIONS						
Valve model	PRV57 PRV57i		PRS57 PRS57i		PRV57E / PRS57E PRV57iE / PRS57iE	
Body design conditions	PN 16	PN 40	PN 16	PN 40	PN 16	PN 40
Maximum upstream pressure	13 bar	28 bar	13 bar	17 bar	10 bar	10 bar
Maximum downstream pressure	13 bar	17 bar	13 bar	17 bar	10 bar	10 bar
Minimum downstream pressure *	0,35	0,35	0,35	0,35	0,35	0,35
Maximum operating temperature	250 °C	250 °C	250 °C	250 °C	180 °C	180 °C
Maximum reducing ratio	See capacity tables					
Rangeability	10:1	10:1	10:1	10:1	10:1	10:1
Maximum hydraulic factory valve body test	24 bar	60 bar	24 bar	60 bar	24 bar	60 bar

\* 0,07 bar with low pressure top (limited to 7 bar maximum inlet pressure).

Remark: Pressure and temperature limiting conditions may change if "G" version for compressed air and gases is chosen or soft sealing/piston rings are used.

REGULATING RANGES				
SPRING COLOUR	GREEN w/ 1 diaphragm	BLUE w/ 1 diaphragm	RED w/ 2 diaphragms	BLACK w/ 2 diaphragms
Regulating range	0,07 to 0,5 bar * 0,35 to 2 bar	1,5 to 5,5 bar	3,5 to 8,5 bar	7 to 17 bar

\* With low pressure top.

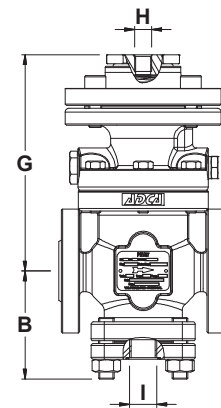
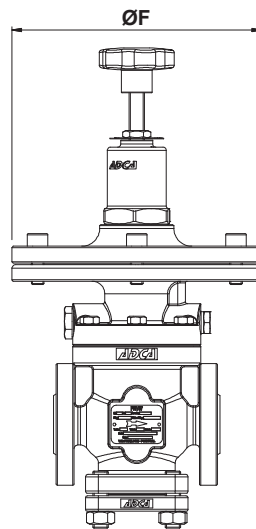
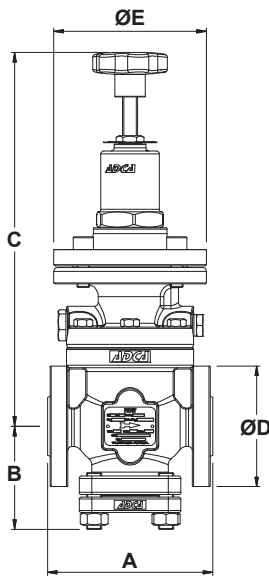

Fig. 1 - Valve with standard diaphragm

Fig. 2 - Valve with low pressure top

Fig. 3 - Dome loaded valve

DIMENSIONS (mm)										
SIZE	A	B	C	D	ØE	ØF	G	H	I *	WEIGHT (kg) **
DN 15	130	88	294	95	120	195	166	1/4"	1/2"	10,5
DN 20	150	88	294	105	120	195	166	1/4"	1/2"	16
DN 25	160	88	294	115	120	195	166	1/4"	1/2"	17
DN 32	180	102	306	140	120	195	178	1/4"	1/2"	20
DN 40	200	108	314	150	120	195	186	1/4"	1/2"	24
DN 50	230	118	351	165	120	195	223	1/4"	1/2"	31
DN 65 ***	290	147	377	185	120	195	249	1/4"	1/2"	48
DN 80	310	152	392	200	120	195	264	1/4"	1/2"	53
DN 100	350	168	422	235	120	195	294	1/4"	1/2"	72

\* Optional drain connection for steam trapping. This drain connection does not replace the humidity separator, but can be useful if, e.g., the valve stops operating for large periods of time (see Fig. 6).

\*\* Approximated values, consult manufacturer for certified weights.

\*\*\* Standard PN 16 DN 65 flanges are supplied with 4 holes. 8 holes, according to EN 1092-1/-2, on request.

Remarks: Connections H and I are threaded ISO 7 Rp. Others on request.

MATERIALS

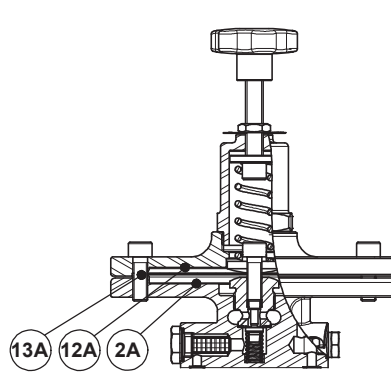
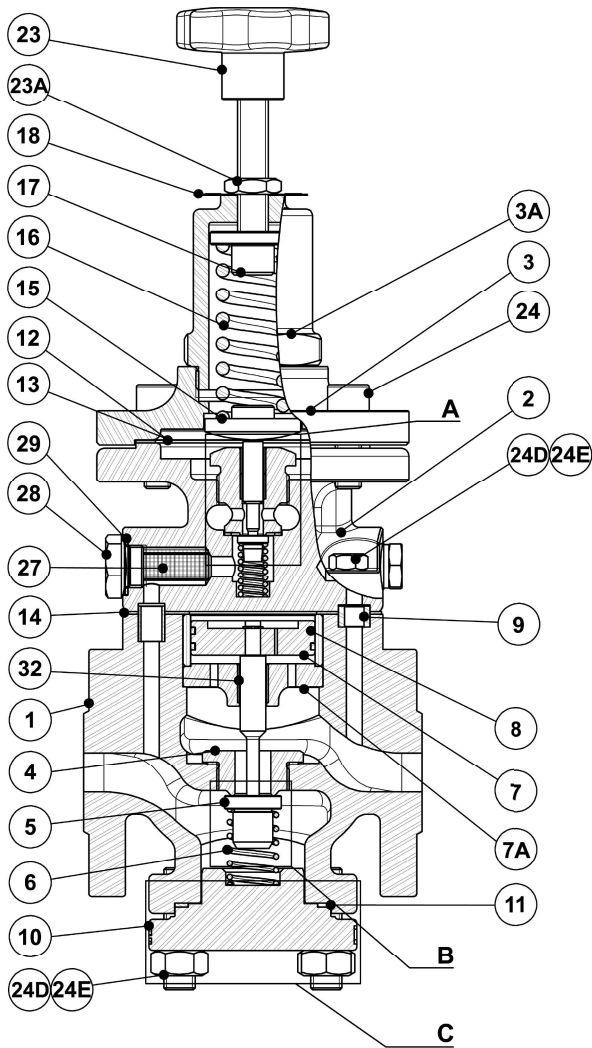

Low pressure top

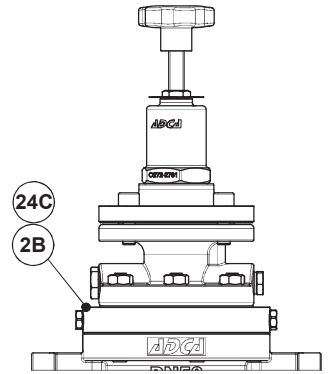

Adapting flange  
(DN 50 and above)

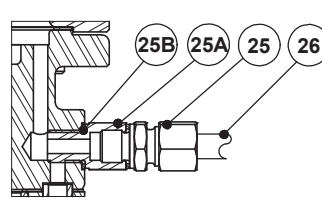

External sensing

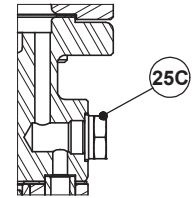

Internal sensing

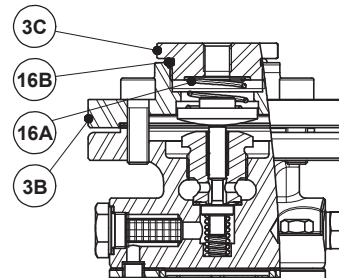

Dome loaded top

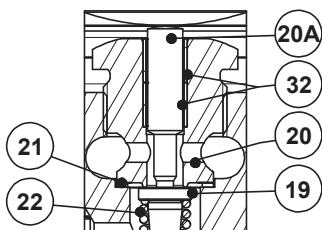

Detail A  
Pilot valve

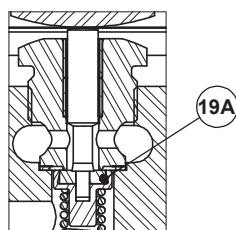

Detail A  
Pilot valve (soft)

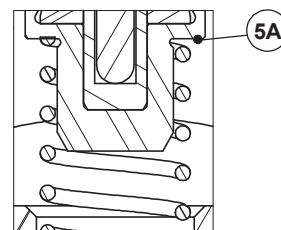

Detail B  
Main valve (soft)

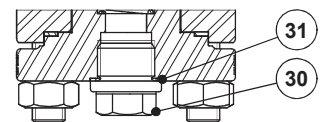

Detail C  
Optional drain connection

**MATERIALS**

POS. N°	DESIGNATION	PRV57	PRV57i
1	Valve body	A216 WCB / 1.0619	A351 CF8M / 1.4408
2	Pilot valve body	A351 CF8 / 1.4308	A351 CF8 / 1.4308
2A	Low pressure pilot valve body	A351 CF8 / 1.4308	A351 CF8 / 1.4308
2B	Adapting flange	C45E / 1.1191	AISI 316 / 1.4401
3	Top cover	A351 CF8 / 1.4308	A351 CF8 / 1.4308
3A	Spring cover	A351 CF8 / 1.4308	A351 CF8 / 1.4308
3B	Top cover	C45E / 1.1191	AISI 316 / 1.4401
3C	Cover nut	C45E / 1.1191	AISI 316 / 1.4401
4	* Main valve seat	AISI 316 / 1.4401	AISI 316 / 1.4401
5	* Main valve plug	Hardened st. steel	Hardened st. steel
5A	* Main valve plug (soft)	AISI 316 w/ PTFE/GR; Rulon	AISI 316 w/ PTFE/GR; Rulon
6	* Main valve spring	AISI 302 / 1.4300	AISI 302 / 1.4300
7	* Piston	Bronze B62 / ASTM B148.97	Bronze B62 / ASTM B148.97
7A	Piston guide	AISI 316 / 1.4401	AISI 316 / 1.4401
8	* Piston Rings	Bronze / FKM / EPDM / NBR	Bronze / FKM / EPDM / NBR
9	Piston liner	AISI 304 / 1.4301	AISI 304 / 1.4301
10	Bottom cover	A216 WCB / 1.0619	A351 CF8M / 1.4408
11	* Bottom cover gasket	Stainless steel / Graphite	Stainless steel / Graphite
12	* Diaphragm	AISI 301 / 1.4310	AISI 301 / 1.4310
12A	* Low pressure diaphragm	AISI 301 / 1.4310	AISI 301 / 1.4310
13	* Diaphragm gasket	Stainless steel / Graphite	Stainless steel / Graphite
13A	* Low press. diaphragm gasket	Stainless steel / Graphite	Stainless steel / Graphite
14	* Pilot valve gasket	Stainless steel / Graphite	Stainless steel / Graphite
15	Lower spring carrier	Brass	Brass
16	* Adjustment spring	Steel	Steel
16A	Diaphragm spring	Stainless steel	Stainless steel
16B	O-ring	Viton	Viton
17	Top spring carrier	Brass	Brass
18	Spring ID plate	Aluminium	Aluminium
19	* Pilot valve plug	AISI 316 / 1.4401	AISI 316 / 1.4401
19A	* Pilot valve plug (soft)	PTFE/GR; Rulon, etc.	PTFE/GR; Rulon, etc.
20	* Pilot valve seat	AISI 316 / 1.4401	AISI 316 / 1.4401
20A	Pushrod	AISI 316 / 1.4401	AISI 316 / 1.4401
21	* Pilot valve gasket	Copper	Copper
22	* Pilot valve spring	AISI 302 / 1.4300	AISI 302 / 1.4300
23	Handwheel	Plastic / Stainless steel	Plastic / Stainless steel
23A	Locknut	AISI 304 / 1.4301	AISI 304 / 1.4301
24	Bolts	ISO 898 or EN 10269 steel	ISO 3506 stainless steel
24C	Bolts	ISO 898 or EN 10269 steel	ISO 3506 stainless steel
24D	Studs	ISO 898 or EN 10269 steel	ISO 3506 stainless steel
24E	Nuts	ISO 898 or EN 10269 steel	ISO 3506 stainless steel
25	Compression fitting	Plated carbon steel	Stainless steel
25A	Adapter	AISI 304 / 1.4301	AISI 304 / 1.4301
25B	Plug	AISI 304 / 1.4301	AISI 304 / 1.4301
25C	Gasket	Copper	Copper
26	Sensing pipe	Copper	Stainless steel
27	* Pilot valve strainer	AISI 304 / 1.4301	AISI 304 / 1.4301
28	Strainer nut	AISI 304 / 1.4301	AISI 304 / 1.4301
29	Gasket	Copper	Copper
30	Plug	AISI 316 / 1.4401	AISI 316 / 1.4401
31	Gasket	Copper	Copper
32	Plain bearing	Bronze / steel	Bronze / steel

\* Available spare parts.

MATERIALS		
POS. N°	DESIGNATION	MATERIAL
100	Sensing pipe	Copper or stainless steel
101	Compressed air supply	Copper or stainless steel
102	P10 air filter regulator	Polycarbonate
103	Solenoid valve	Brass or stainless steel
104	ADCA IS100 filter	AISI 316 / 1.4401
105	ADCA PS7 pressure sustaining valve	Carbon steel or stainless steel
106	Drain connection	Copper or stainless steel

## STANDARD VALVE FOR STEAM, COMPRESSED AIR AND OTHER GASES

The high pressure upstream gas enters the main valve and the pilot valve. Compression of the regulating spring over the diaphragm causes the pilot valve to open, admitting regulated pressure to the piston chamber. The force exerted by the regulated pressure on top of the piston pushes it down which, in turn, opens the main valve. The downstream pressure is then transmitted through the sensing line, acting below the diaphragm.

Any downstream pressure increase deflects the diaphragm, and the pilot valve closes, thus shutting off regulated gas to the piston which, in turn, closes the main valve. When the desired downstream pressure is achieved, the valve opens again, repeating the process.

The external sensing pipe (100) must always be connected unless the valve is supplied with internal sensing line. It should be fitted in the downstream pipe at a distance of, at least, 1 meter or 15 pipe diameters, whichever is greater, from the valve and other fittings. A spool piece can be supplied to house the sensing pipe.

**Warning:** Internal sensing is not recommended when:

- The reduced pressure is below 50% of the inlet pressure (mandatory for pressure reductions greater than 10:1);
- Instability of reduced pressure occurs;
- When a low pressure top assembly is fitted;
- In systems with difficult outlet pipe work conditions.

## DOME LOADING

The loading force is exerted on the pilot valve diaphragm by an external gas signal rather than by the regulating spring. This feature allows remote adjusting of the downstream set point pressure using a relieving gas pressure regulator or an I/P converter. Allows faster response to pressure changes and maintains outlet pressure more accurately under flowing conditions, when compared to the standard spring loaded version, minimizing droop.

The loading control pressure is approximately the same as the required outlet pressure ( $\pm 0,2$  bar).

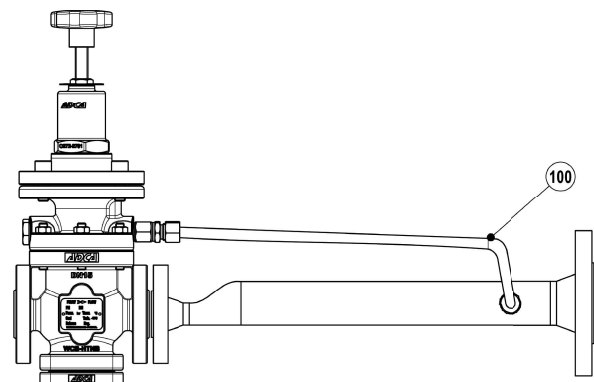

Fig. 4 - Standard valve

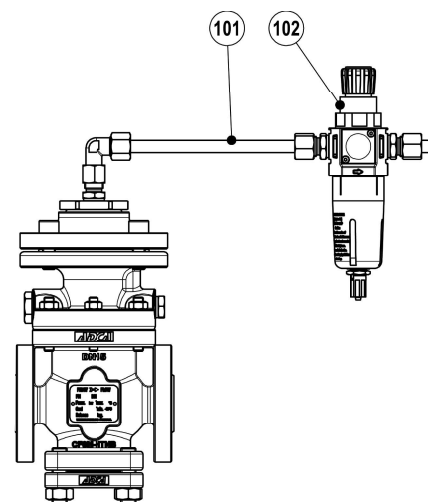

Fig. 5 - Dome loaded valve

## DRAIN CONNECTION

The optional drain connection is specially recommended for steam applications where it is not possible to install a humidity separator close to the valve, when the valve is under no-flow static condition during large periods of time or for system cleaning during start up.

## VALVE WITH SOLENOID VALVE FOR REMOTE CLOSURE (PRV47E)

The PRV57E operates like the standard valve, but it allows remote closure, by means of a switch or timer. When the solenoid valve (103) closes, the pressure signal to the pilot valve is interrupted, causing the main valve to close.

TECHNICAL DATA (SOLENOID VALVE)	
Body material	Brass or stainless steel
Maximum operating pressure	10 bar
Maximum operating temperature	180 °C
Level of protection	IP 65
Rated voltage	230 V AC $\pm 10\%$ , 24 V DC $\pm 10\%$ *
Power consumption	12 VA $\pm 10\%$ (AC), 12 W $\pm 10\%$ (DC)

\* Others on request.

## PRESSURE REDUCING AND SUSTAINING VALVE (PRS47)

The PRS57 is a derivative of the PRV57 and consists in a combination between a pressure reducing valve and a pressure sustaining valve. While the pilot fitted on the main valve body controls downstream pressure, a secondary pilot valve (105), in this case a pressure sustaining valve, fitted on the side of the PRV controls the upstream pressure. The pressure sustaining valve is closed until the established set pressure is reached and so is the main valve, since there is no flow feeding its pilot. As soon as the set pressure is reached, the pressure sustaining valve opens, allowing flow to the PRV's pilot valve which, in turn, opens the main valve.

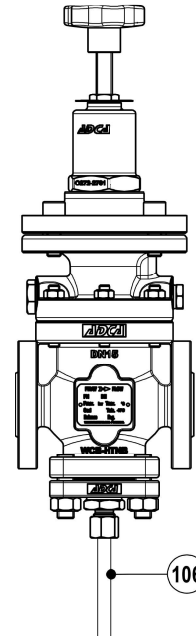

Fig. 6 - Valve with drain connection

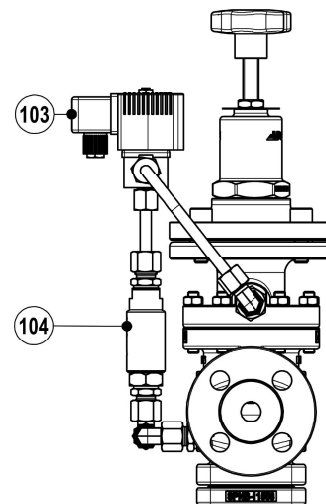

Fig. 7 - Valve with solenoid valve for remote closure

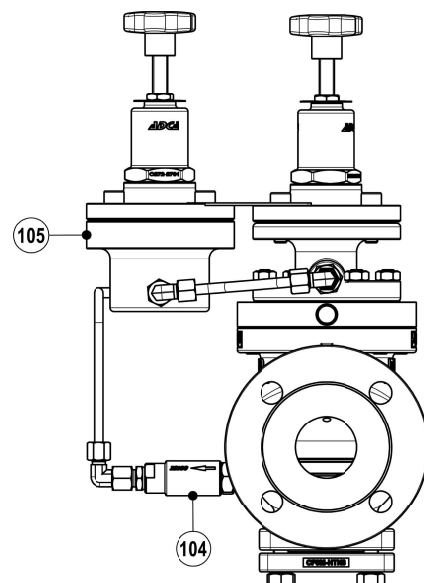

Fig. 8 - Pressure reducing and sustaining valve



ORDERING CODES PRV57											
<b>Valve model</b>	V57	X	X	S	1	X	X	1	L	15	
PRV57 – steam (standard)	V57										
PRV57G – compressed air and gases	V57G										
<b>Construction material</b>											
Carbon steel construction		X									
Stainless steel construction		I									
<b>Options</b>											
Standard valve for external sensing connection											XX
Valve with internal sensing line											OX
Solenoid valve for remote closure and external sensing connection a)											EX
Solenoid valve for remote closure with internal sensing line a)											EO
Pressure sustaining / reducing for external sensing connection b)											SX
Pressure sustaining / reducing with internal sensing line b)											SO
Pressure sustaining / reducing / solenoid for external sensing connection a)											YX
Pressure sustaining / reducing / solenoid with internal sensing line a)											YO
<b>Diaphragm</b>											
Standard diaphragm											S
Low pressure diaphragm											L
<b>Regulating range</b>											
Green spring 0,35 to 2 bar – single diaphragm											1
Blue spring 1,5 to 5,5 bar – single diaphragm											2
Red spring 3,5 to 8,5 bar – double diaphragm											3
Black spring 7 to 17 bar – double diaphragm											4
Dome loaded – 0,35 to 4 bar – single diaphragm c)											6
Dome loaded – 2 to 17 bar – double diaphragm c)											7
<b>Piston rings</b>											
Bronze											X
FKM d)											V
EPDM d)											E
NBR d)											N
<b>Drain connection</b>											
Standard valve											X
Drain connection ISO 7 Rp 1/2"											D
<b>Valve sealing</b>											
Standard metal to metal with hardened plug											1
Stellited plug and seat											2
Soft sealed with virgin PTFE d)											3
Soft sealed with PTFE/GR d)											4
Soft sealed with Rulon d)											5
Soft sealed with FPM/Viton d)											6
<b>Pipe connection</b>											
Flanged EN 1092-1 PN 16											L
Flanged EN 1092-1 PN 40											N
<b>Size</b>											
DN 15											15
DN 20											20
DN 25											25
...											
<b>Special valves / Extras</b>											
Full description or additional codes have to be added in case of non-standard combination.											E

a) Solenoid valve voltage must be specified.

b) ADCA PS7 pressure sustaining valve. See respective datasheet for regulating range and further information.

c) The loading control pressure is approximately the same as the required downstream pressure ( $\pm 0,2$  bar).

d) Valve limited to the materials maximum operating temperature. Contact manufacturer for more details.