

PRESSURE REDUCING VALVE RPW45B (EN)

DESCRIPTION

The ADCA RPW45B series pressure reducing valves are single seated, diaphragm sensing proportional controllers that operate without auxiliary energy.

Designed for use with water, compressed air and other liquids and gases compatible with the construction.

MAIN FEATURES

Pressure balancing through robust piston design.

Soft sealing to meet tight shut-off requirements.

Robust construction (fit-and-forget).

Interchangeable actuators and adjustment springs.

OPTIONS: Low-noise flow divider.
Sensing pipe on body.

USE: Water, compressed air and other liquids or gases compatible with the construction.

AVAILABLE MODELS: RPW45BG – SG iron.
RPW45BS – carbon steel.
RPW45Bi – stainless steel.

SIZES: DN 50 to DN 100.

CONNECTIONS: Flanged EN 1092-1 PN 16 or PN 40.
Standard PN 16 DN 65 flanges are supplied with 4 holes. 8 holes, according to EN 1092-1/-2 on request.

AVAILABLE ACTUATORS: A1, A10, A12, A3 and A4 – carbon steel.
A2 and A21 – SG iron or carbon steel.
A1i, A10i, A12i, A2i, A21i, A3i and A4i – stainless steel.

INSTALLATION: See IMI – Installation and maintenance instructions.



RPW45BS



RPW45Bi



**RPW45BS
with sensing pipe
on body**

CE MARKING – GROUP 2 (PED – European Directive)

PN 16	PN 40	Category
DN 50	–	SEP
DN 65 to 100	DN 50 to 100	1 (CE marked)

LIMITING CONDITIONS				
Valve model	RPW45BG	RPW45BS	RPW45BS	RPW45Bi
Body design conditions	PN 16	PN 16	PN 40	PN 40
Maximum upstream pressure	16 bar	16 bar	40 bar	40 bar
Maximum downstream pressure	13 bar	13 bar	18 bar	18 bar
Minimum downstream pressure	0,2 bar	0,2 bar	0,2 bar	0,2 bar
Maximum operating temperature	130 °C	130 °C	130 °C	130 °C
Maximum reducing ratio	10:1	10:1	10:1	10:1
Rangeability	10:1	10:1	10:1	10:1
Maximum hydraulic factory valve body test	24 bar	24 bar	60 bar	60 bar

Remark: Other soft materials and temperature limits on request.

Actuator model	A1 A1i	A10 A10i	A12 A1i	A21 A21i	A2 A2i	A3 A3i	A4 A4i
Maximum operating pressure (bar)	25	25	25	18	12	2,5	1,5
Maximum operating temperature	90 °C *						

* With liquids at higher temperature, the sensing pipe should prevent exceeding the maximum operating temperature of the actuator.

FLOW RATE COEFFICIENTS (m³/h)				
SIZE	DN 50	DN 65	DN 80	DN 100
Kvs	26,5	51,5	79,5	129,5

ACTUATOR AND SPRING SELECTION TABLE									
SIZE		ACTUATOR							
		A4 A4i	A3 A3i	A2 A2i	A21 A21i	A1 A1i	A10 A10i	A12 A12i	
DN 50	Regulating range (bar)	0,2 to 0,5	0,4 to 1	0,7 to 1,6	1,4 to 3,5	2,5 to 5,5	3,5 to 8	5 to 10	8 to 18
	Spring N°	67	61	61	61	61	61	61	61
DN 65	Regulating range (bar)	0,2 to 0,5	0,4 to 1	0,7 to 1,6	1,4 to 3,5	2,5 to 5,5	3,5 to 8	5 to 10	8 to 18
	Spring N°	67	61	61	61	61	61	61	61
DN 80	Regulating range (bar)	0,2 to 0,5	0,4 to 1,2	0,7 to 2	1,8 to 4,5	2,5 to 5,5	3,5 to 9	5 to 12	10 to 18
	Spring N°	68	62	62	62	62	62	62	62
DN 100	Regulating range (bar)	0,2 to 0,6	0,4 to 1,2	0,7 to 2	1,8 to 4,5	2,5 to 5,5	3,5 to 9	5 to 12	10 to 18
	Spring N°	69	63	63	63	63	63	63	63

HOW TO SIZE (USING Kvs)

Please consult formulas on IS PV10.00 E or consult manufacturer.

HOW TO ORDER

RPW45BS DN 80 PN 16 valve complete with spring N° 62, A2 actuator with sensing pipe on body.

INSTALLATION

Horizontal installation with the actuator vertically, pointing downwards (recommended, especially for liquid service) or upwards.

The sensing pipe, if not fitted on the valve body, must be installed downstream of the valve at a minimum of 1 meter away or 15 pipe diameters.

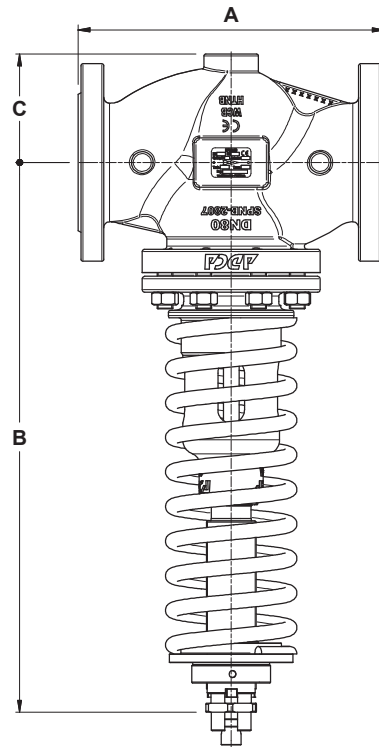

DIMENSIONS – VALVE (mm)				
DIMENSION	SIZE			
	DN 50	DN 65	DN 80	DN 100
A	230	290	310	350
B	470	495	556	597
C	85	100	110	130
WEIGHT (kg)	23,9	37,3	48,1	58,2

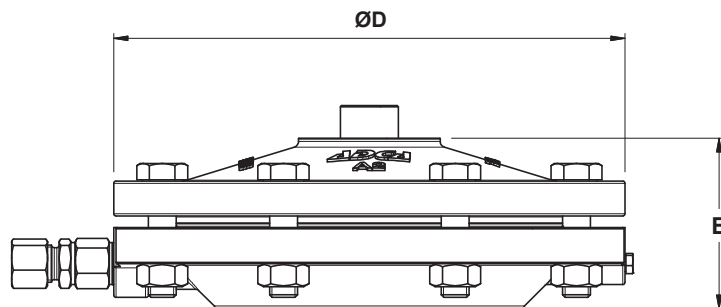

DIMENSIONS – ACTUATOR (mm)							
DIMENSION	ACTUATOR						
	A1 A1i	A10 A10i	A12 A12i	A2 A2i	A21 A21i	A3 A3i	A4 A4i
ØD	172	172	172	220	220	282	340
E	67	67	67	74	74	71	81
WEIGHT (kg)	4,3	4,3	4,3	7,3	7,3	11,3	16,3

MATERIALS

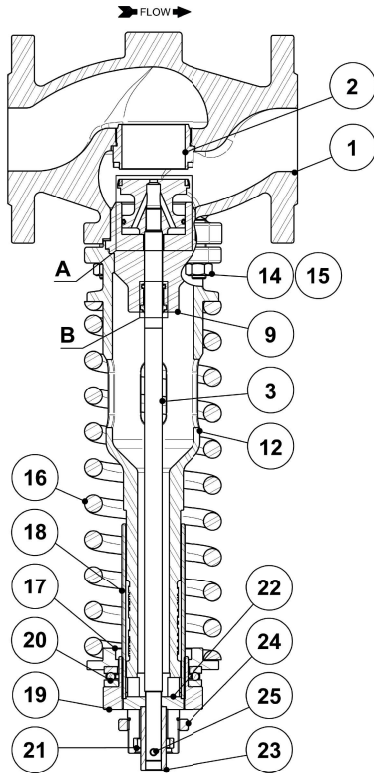

DN 50

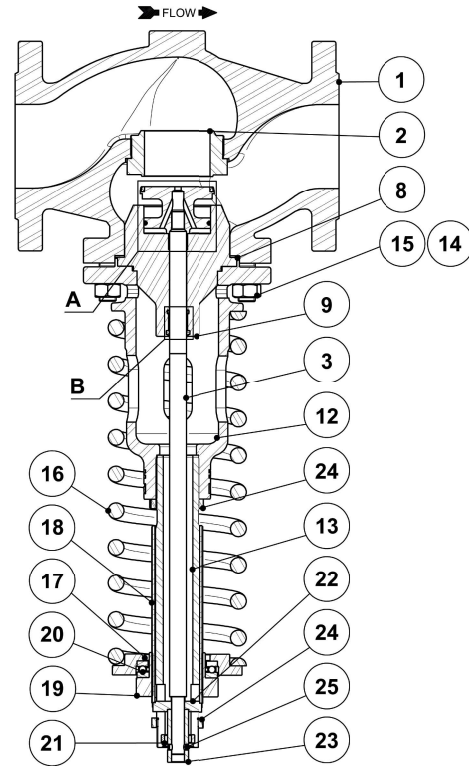

DN 65 to DN 100

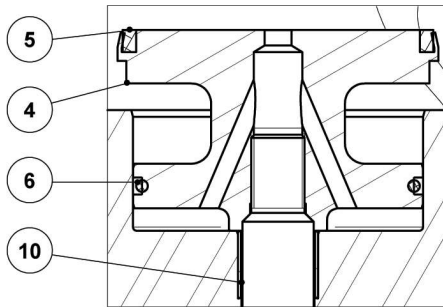

Detail A

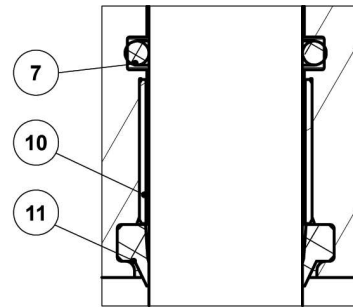

Detail B

MATERIALS – VALVE

POS. N°	DESIGNATION	DN 50	DN 65 to DN 100
1	Valve body (RPW45BG)	GJS-400-15 / 0.7040	GJS-400-15 / 0.7040
	Valve body (RPW45BS)	A216 WCB / 1.0619	A216 WCB / 1.0619
	Valve body (RPW45Bi)	A351 CF8M / 1.4408	A351 CF8M / 1.4408
2	Seat	AISI 316 / 4.4401	AISI 316 / 4.4401
3	Stem	AISI 304 / 1.4301	AISI 304 / 1.4301
4	* Valve plug	AISI 316 / 4.4401	AISI 316 / 4.4401
5	Seal ring	EPDM	EPDM
6	O-ring	EPDM	EPDM
7	O-ring	EPDM	EPDM
8	Gasket	Stainless steel / Graphite	Stainless steel / Graphite
9	Stem guide	AISI 304 / 1.4301	AISI 304 / 1.4301
10	Guide bushing	Steel	Steel
11	Scraper	Viton	Viton
12	Piston body (RPW45BG and RPW45BS)	A216 WCB / 1.0619	A216 WCB / 1.0619
	Piston body (RPW45Bi)	A351 CF8M / 1.4408	A351 CF8M / 1.4408
13	Piston body extension (RPW45BG and RPW45BS)	–	P355T1 / 1.0421
	Piston body extension (RPW45Bi)	–	AISI 304 / 1.4301
14	Studs (RPW45BG and RPW45BS)	Steel 8.8; EN 10269 steel	Steel 8.8; EN 10269 steel
	Studs (RPW45Bi)	Stainless steel A2-70	Stainless steel A2-70
15	Nuts (RPW45BG and RPW45BS)	Steel 8.8; EN 10269 steel	Steel 8.8; EN 10269 steel
	Nuts (RPW45Bi)	Stainless steel A2-70	Stainless steel A2-70
16	* Adjustment spring	Spring steel	Spring steel
17	Lower spring plate (RPW45BG and RPW45BS)	C45E / 1.1191	C45E / 1.1191
	Lower spring plate (RPW45Bi)	AISI 304 / 1.4301	AISI 304 / 1.4301
18	Threaded tube	CuZn39Pb3	CuZn39Pb3
19	Spring adjusting nut (RPW45BG and RPW45BS)	C45E / 1.1191	C45E / 1.1191
	Spring adjusting nut (RPW45Bi)	AISI 304 / 1.4301	AISI 304 / 1.4301
20	Ball bearing	Zinc plated steel	Zinc plated steel
21	Spacer (RPW45BG and RPW45BS)	S355J2G3 / 1.0570	S355J2G3 / 1.0570
	Spacer (RPW45Bi)	AISI 304 / 1.4301	AISI 304 / 1.4301
22	Pressure star (RPW45BG and RPW45BS)	S235JR / 1.0038	S235JR / 1.0038
	Pressure star (RPW45Bi)	AISI 304 / 1.4301	AISI 304 / 1.4301
23	Pressure tube (RPW45BG and RPW45BS)	C45E / 1.1191	C45E / 1.1191
	Pressure tube (RPW45Bi)	AISI 304 / 1.4301	AISI 304 / 1.4301
24	Lock nut (RPW45BG and RPW45BS)	C45E / 1.1191	C45E / 1.1191
	Lock nut (RPW45Bi)	AISI 303 / 1.4305	AISI 303 / 1.4305
25	Pin	AISI 303 / 1.4305	AISI 303 / 1.4305

* Available spare parts.

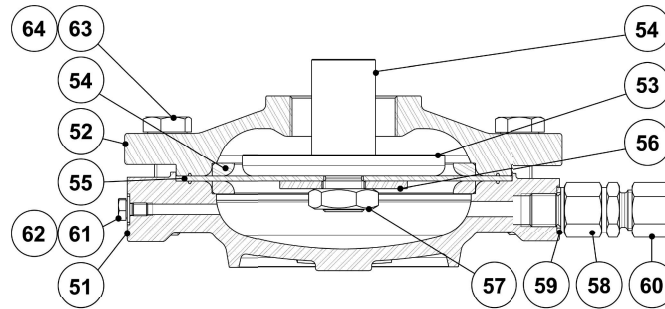

A series

MATERIALS – ACTUATOR				
POS. N°	DESIGNATION	A1, A10, A12, A3 and A4	A2 and A21	A1i, A10i, A12i, A2i, A21i, A3i and A4i
51	Lower diaphragm chamber	A216 WCB / 1.0619	GJS-400-15 / 0.7040 A216 WCB / 1.0619	A351 CF8M /1.4408
52	Upper diaphragm chamber	A216 WCB / 1.0619	GJS-400-15 / 0.7040 A216 WCB / 1.0619	A351 CF8M /1.4408
53	Pressure plate	A216 WCB / 1.0619	GJS-400-15 / 0.7040	A351 CF8M /1.4408 AISI 304 / 1.4301
54	Diaphragm plate spindle	A216 WCB / 1.0619	GJS-400-15 / 0.7040	A351 CF8M /1.4408 AISI 304 / 1.4301
55	* Diaphragm	Neoprene reinforced polyamid	Neoprene reinforced polyamid	Neoprene reinforced polyamid
56	Washer	Copper	Copper	AISI 304 / 1.4301
57	Hex nut	CuZn39Pb3	CuZn39Pb3	AISI 304 / 1.4301
58	Flow restrictor	AISI 303 / 1.4305	AISI 303 / 1.4305	AISI 303 / 1.4305
59	Gasket	Copper	Copper	Copper
60	Compression fitting	AISI 316Ti / 1.4571	AISI 316Ti / 1.4571	AISI 316Ti / 1.4571
61	Vent screw	Zinc plated steel	Zinc plated steel	AISI 304 / 1.4301
62	Washer	Copper	Copper	AISI 304 / 1.4301
63	Bolts	Zinc plated steel	Zinc plated steel	AISI 304 / 1.4301
64	Nuts	Zinc plated steel	Zinc plated steel	AISI 304 / 1.4301

* Available spare parts.