

TEMPERATURE REGULATORS
SELF ACTING - NON BALANCED SIMPLE SEAT
TR25SS stainless steel valves & T series thermostats

DESCRIPTION

The TR25 valves series were designed for direct acting temperature control systems where the valve closes on temperature rising. They are single seated, in order to ensure an excellent tightness and are intended to be coupled with the thermostat models T.205 and T.405. The liquid filling the thermostat expands when the temperature levels of the fluid being heated rise, closing the valve.

These valves are used for controlling the temperature in central heating systems, district heating systems and industrial plants.

MAIN FEATURES

Single seated, two way, direct action valve.
 Leakage less than 0,05% of full Kv.

OPTIONS: Valves for cooling applications.

USE: Saturated and superheated steam.
 Hot and superheated water.

AVAILABLE MODELS: TR25SS – Stainless steel construction valve body.

SIZES: 1/2" to 1".

CONNECTIONS: Female screwed ISO 7/1 Rp (BS 21) .

CONTROL MODE: Proportional.

THERMOSTATS: T.205 - 200N (max. closing force);
 T.405 - 400N (max. closing force).

THERMOSTAT RANGES: T.205 - 0-60; 30-90 and 60-120°C;
 T.405 - 0-120; 40-160 °C.

CAPILLARY LENGTHS: 3 m as standard.

HOW TO SELECT: Never size the valve according to the pipe diameter in which it has to be fitted but according to the required actual flow of steam or water. Refer to valve calculation data sheet or consult the factory.

INSTALLATION:

Horizontal installation with the thermostat in the vertical position, in order to reduce wear. In case of valve temperatures up to 150 °C, the thermostat may be fitted below or above the valve. In case of valve temperatures between 150 and 250 °C, a cooling K1 type unit has to be applied with connection downwards. An "Y" strainer should be installed upstream of the valve.

See IMI – Installation and maintenance instructions.

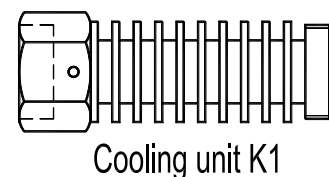
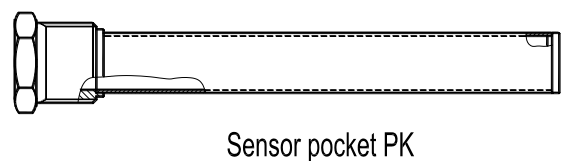
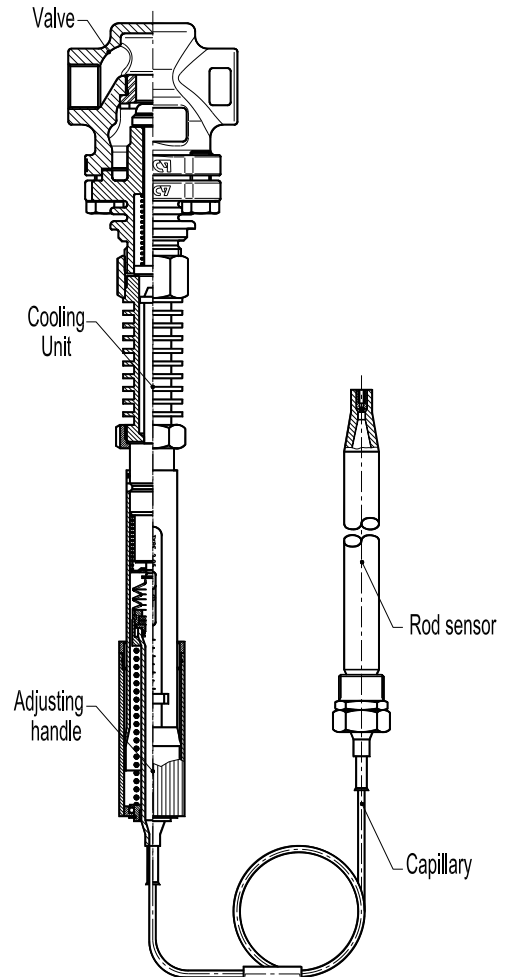

SPECIFICATIONS				
TYPE	CONNECT. DN	OPENING Ø (mm)	Kvs (m³/h)	VALVE STROKE
TR25 – 15/4	15	4	0,2	6
TR25 – 15/6	15	6	0,45	6
TR25 – 15/9	15	9	0,95	6
TR25 – 15/12	15	12	1,7	6
TR25 – 15	15	15	2,75	6
TR25 – 20/9	20	9	0,95	6,5
TR25 – 20/15	20	15	2,75	6,5
TR25 – 20/20	20	20	5	6,5
TR25 – 25/20	25	20	5	7
TR25 – 25/25	25	25	7,5	7

MAX. PERMISSIBLE DIF. PRESSURES		
WITH T.205 THERMOSTAT		
PRESS. (bar)	VALVE SIZE (DN)	SEAT Ø (mm)
21	15	4 and 6
13	15	9
9,3	15	12
5,3	15	15
5,3	20	15
2,9	20	20
2,9	25	20
1,3	25	25

MAX. PERMISSIBLE DIF. PRESSURES		
WITH T.405 THERMOSTAT		
PRESS. (bar)	VALVE SIZE (DN)	SEAT Ø (mm)
40	15	4 and 6
38	15	9
24	15	12
15	15	15
15	20	15
9	20	20
9	25	20
4,7	25	25

PROPORTIONAL BAND

The proportional band is the temperature change required for the valve to move from fully open to fully closed. It depends on the valve stroke and on the thermostat movement per °C, and is calculated as follows:

Proportional band:
$$\frac{\text{Valve stroke (mm)}}{\text{Thermostat mov. (mm/°C)}}$$

Thermostat movement in mm per °C:

T.205 and T.405: 0,5 mm / °C

A proportional band in the range 8-13°C is suitable for most applications. A smaller proportional band is not ideal where heat load varies rapidly.

DIMENSIONS – THERMOSTAT (mm)					
TYPE	A	B	C	E	WGT. (kg)
T.205	305	405	210	22	1,8
T.405	385	525	390	22	2,6

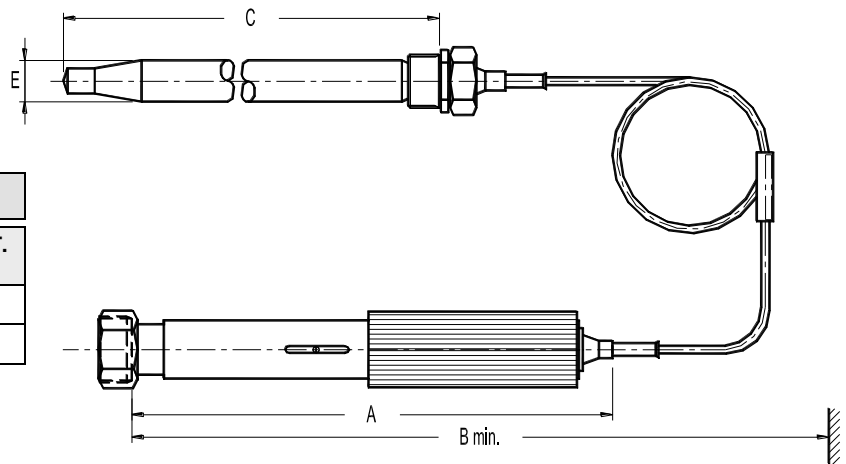

DIMENSIONS – VALVE BODY (mm)					
SIZE	A	B	C	F	WGT. (kg)
1/2"	100	40	112	80	2,8
3/4"	100	40	112	80	2,8
1"	100	40	112	80	2,9

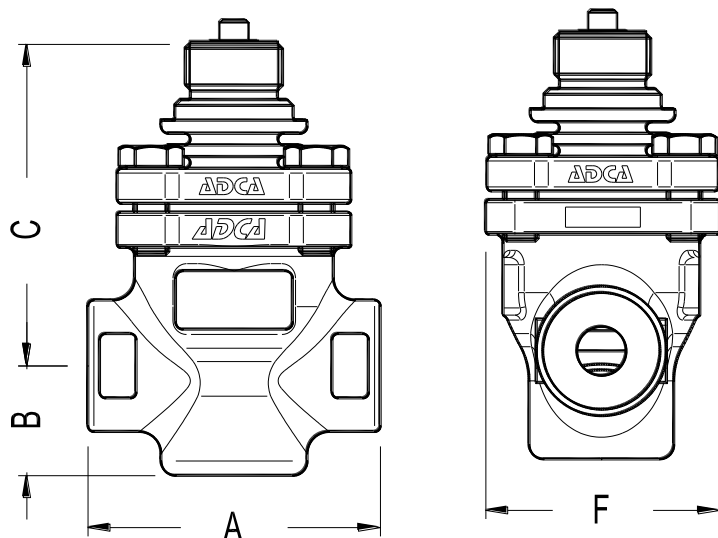

MATERIALS		
POS. Nº	DESIGNATION	MATERIAL
1	Body	CF8M / 1.4408
2	Bonnet	CF8 / 1.4308
3	* Gasket	St. steel / Graphite
4	* Valve plug	AISI 316 / 1.4401
5	Seat	AISI 316 / 1.4401
6	* Spring	AISI 302 / 1.4300
7	Cap	AISI 304 / 1.4301
8	Washer	AISI 304 / 1.4301
9	Bolts	A-2

* Available spare parts.

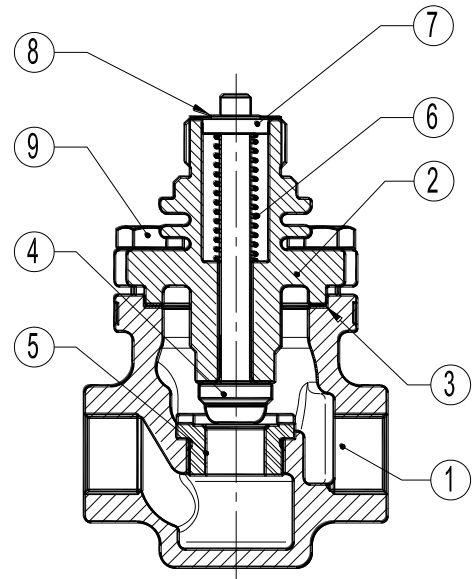

COOLING UNITS K1

The cooling units are used in connection with control valves and thermostats to protect the stuffing box. At valve temperatures between 150°C and 250°C a cooling unit of type K1 connected downwards should be applied.

For higher temperatures as well as for all hot oil systems please consult.

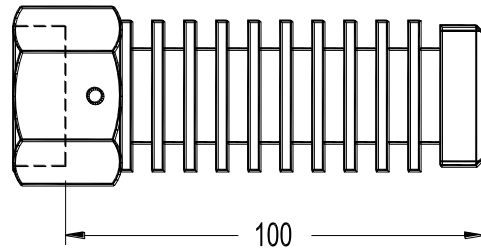

SENSOR POCKETS PK

Sensor pockets made of stainless steel can be supplied to all TR series self-acting thermostats with rod sensors. They are used where it is impossible to empty the system or the tank.

The use of sensor pockets implies delay of heat transfer to the rod sensors and thus a longer reaction time for the controllers. This is, to some extent, counteracted by filling up the sensor pockets with paste or oil.

INSTALLATION

The installation site for the sensor pocket is arbitrary when paste is applied. When using oil, the sensor pocket must point at least slightly downwards.

MATERIAL

Stainless steel 1.4436.

LIMITING CONDITIONS

40 bar at 120 °C;
24 bar at 350 °C.

POCKET DIMENSIONS (mm)					
TYPE	D	H	L	S	R
PK2	25	9	218	36	1"
PK4	25	10	390	45	11/4"

